

KUKA | Xpert

Identification number: AR23951

货号	0000-293-592
材料状态	10 - 批准预生产
制造商	KUKA Roboter
产品图片	

Spare parts

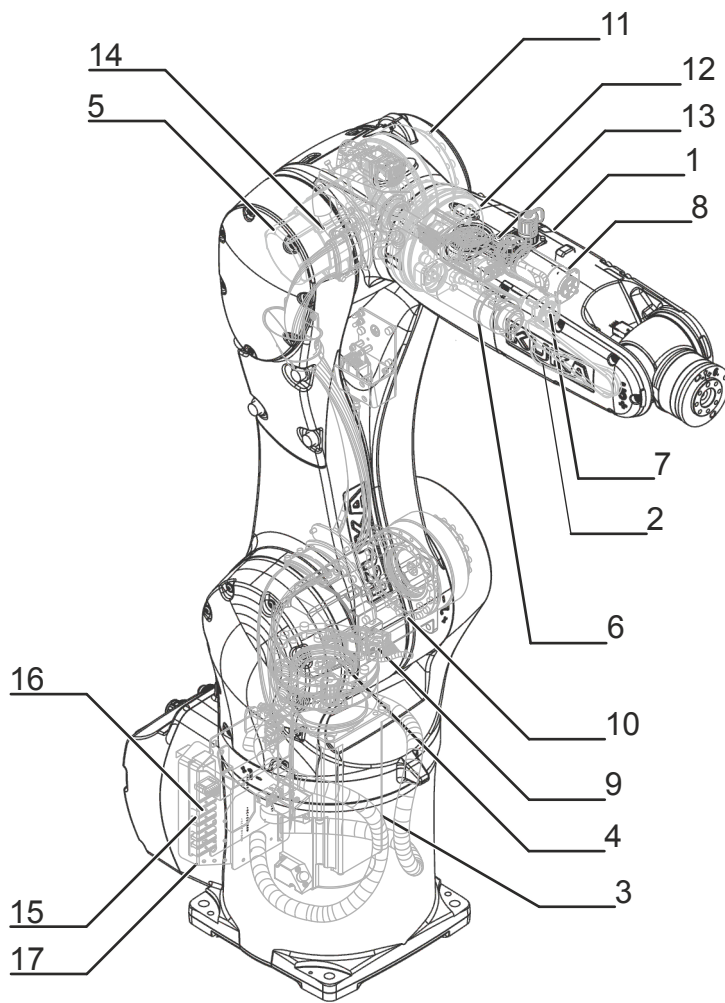

Spare parts graphic – schematic representation

Pos.	Article number	Designation	Component
1	0000-245-278	SPP wrist swivel housing CR assy (wgg)	In-line wrist
2	0000-237-345	SPP wrist belt set CR	Toothed belt
3	0000-244-842	SPP motor A1 CR (w/o G/A)	Motor A1
4	0000-244-857	SPP motor A2 CR (w/o G/A)	Motor A2

Pos.	Article number	Designation	Component
5	0000-244-867	SPP motor A3 CR (w/o G/A)	Motor A3
6	0000-244-902	SPP motor A4 CR assy. (wgg)	Motor A4
7	0000-244-904	SPP motor A5 CR assy.	Motor A5
8	0000-244-908	SPP motor A6 CR assy.	Motor A6
9	0000-244-869	SPP gear unit A1; KR10 CR (w/o F/K)	Gear A1
10	0000-244-890	SPP gear unit A2; KR10 CR (w/o F/K)	Gear A2
11	0000-244-901	SPP gear unit A3; KR10 CR (w/o F/K)	Gear A3
12	0000-244-909	SPP gear unit A4 CR (w/o G/A)	Gear A4
13	0000-245-293	SPP valve unit assy. CR (wgg)	
14	0000-252-379	SPP cable set (wgg) R900 CR	Cable set
15	0000-245-296	SPP RDC CR	RDC
16	0000-245-298	SPP Electronic Data Storage CR (Agilus)	EDS
17	0000-245-297	SPP E/A module CR	
18	0000-200-304	Mini gauge cartridge	Gauge cartridge

Export to Excel 

Maintenance information

Toothed belt tension

Toothed belt tension inline wrist	
A5	205 ± 5 Hz
A6	205 ± 5 Hz

技术数据

基本数据

	KR 10 R900 CR
轴数	6
可控制的轴数	6
工作空间体积	2.85 m ³
位姿重复精度 (ISO 9283)	± 0.03 mm
重量	约 52 kg
额定负荷	5 kg
最大负载能力	10 kg
最大运动范围	901.5 mm
防护等级 (IEC 60529)	IP54
机器人腕部防护等级 (IEC 60529)	IP54
噪声等级	< 70 dB (A)
安装位置	地面; 屋顶; 墙壁; 任意角度
占地面积	320 mm x 320 mm
运动系统安装面布孔图	C246
允许倾角	-
标准色	底座: 交通白 (RAL 9016); 活动部件: 交通白 (RAL 9016); 盖板: 交通白 (RAL 9016)
控制系统	KR C4 smallsize-2; KR C4 compact
变压器名称	KR C4: KR10R900 C4SR

环境条件

湿度等级 (EN 60204)	-
环境条件分类 (EN 60721-3-3)	3K3
环境温度	
运行时	5 °C 至 45 °C (278 K 至 318 K)
仓储和运输时	-40 °C 至 60 °C (233 K 至 333 K)

轴数据

运动范围	
A1	±170 °
A2	-190 ° / 45 °
A3	-120 ° / 156 °
A4	±185 °
A5	±120 °
A6	±350 °
额定负载时的速度	
A1	300 °/s
A2	225 °/s
A3	225 °/s
A4	381 °/s
A5	311 °/s
A6	492 °/s

工作区域

Dimensions: mm

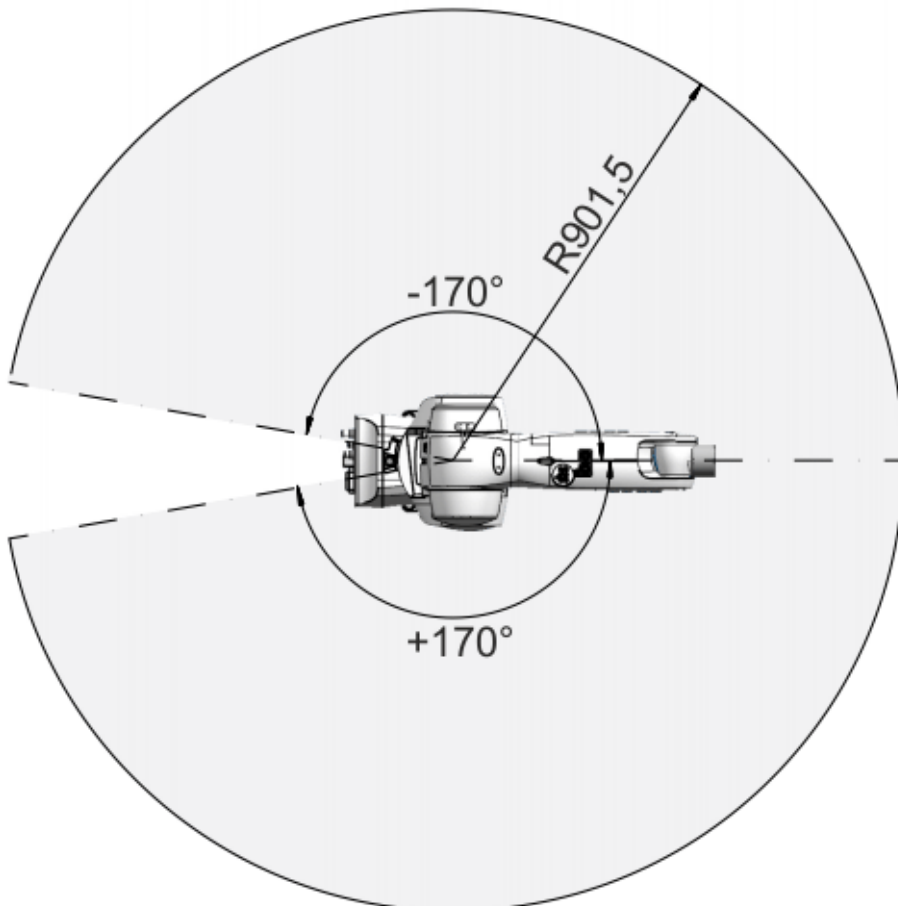
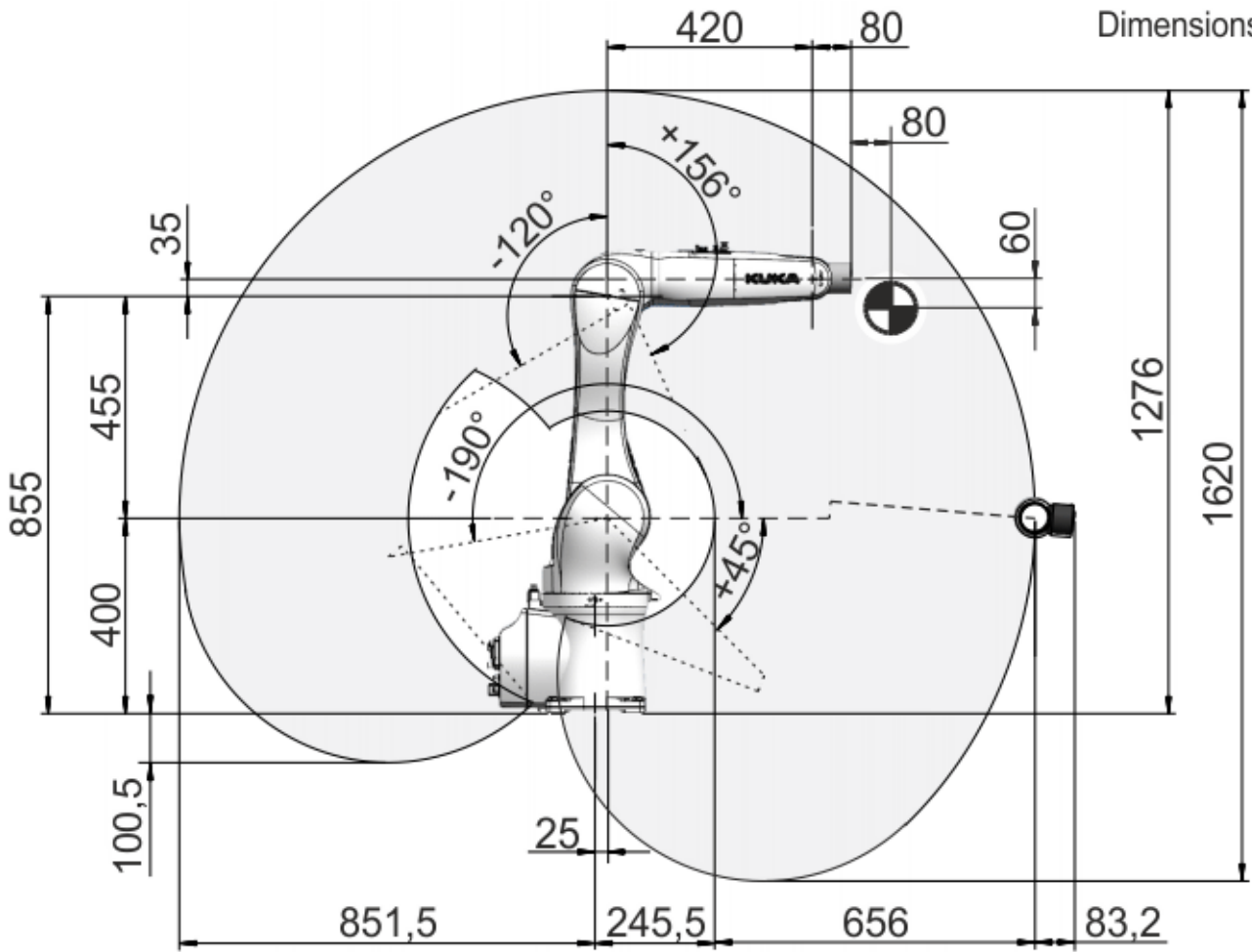

KR 10 R900 CR 工作区域

负载能力

额定负荷	5 kg
最大负载能力	10 kg
法兰 I_x 额定质量转动惯量	0.045 kgm ²
法兰 I_y 额定质量转动惯量	-
法兰 I_z 额定质量转动惯量	-
底座的额定附加负载	0 kg
底座的最大附加负载	10 kg
转盘的额定附加负载	0 kg
旋转机构的最大附加负载	10 kg
大臂的额定附加负载	0 kg
大臂的最大附加负载	10 kg
小臂的额定附加负载	0 kg
小臂的最大附加负载	10 kg
负载重心额定距离	
L_{xy}	100 mm
L_z	80 mm

Dimensions: mm

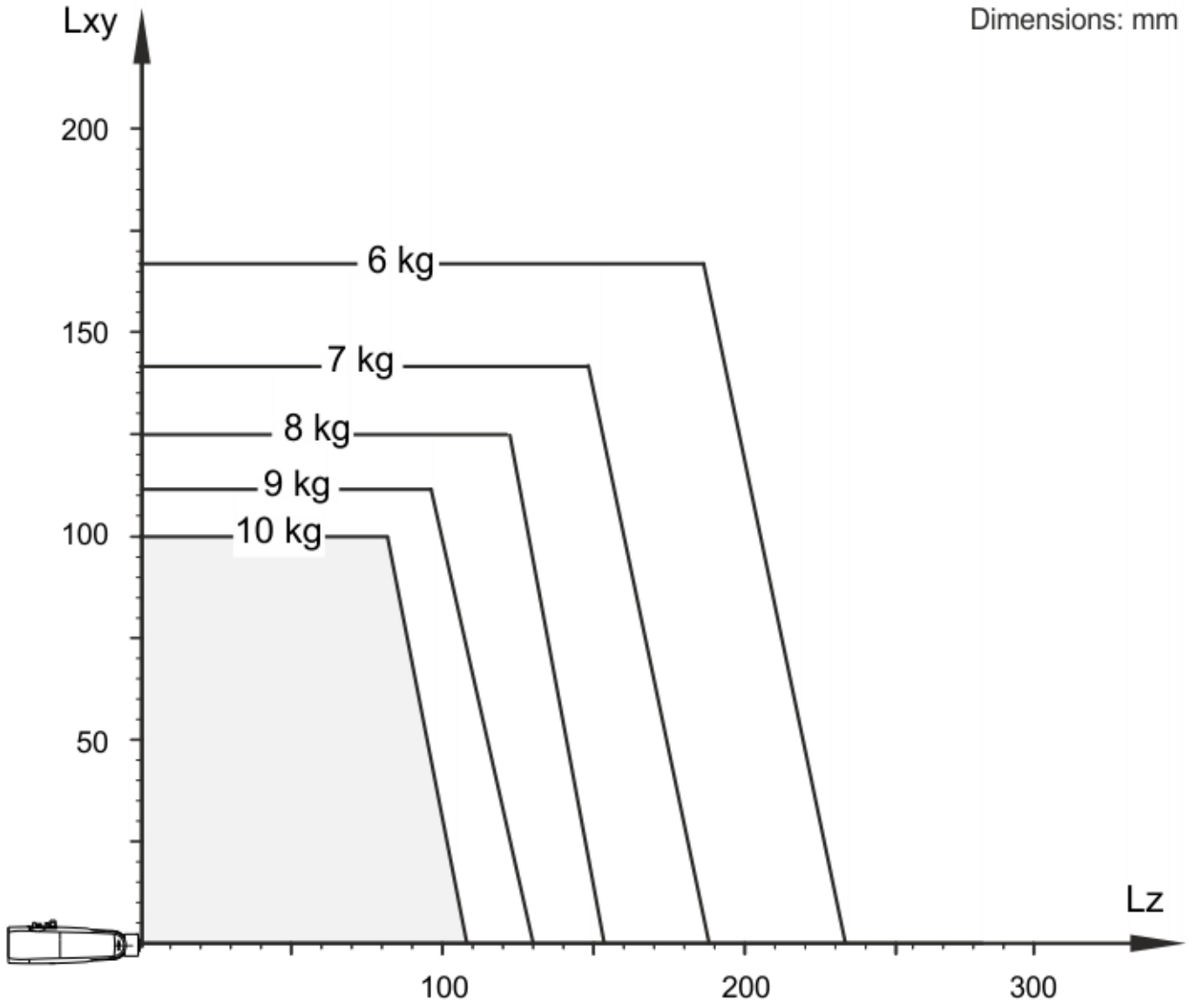

KR 10 R900 CR 负载能力图表

连接法兰

机器人腕部类型	ZH10 R900 CR
连接法兰	见图纸

Dimensions: mm

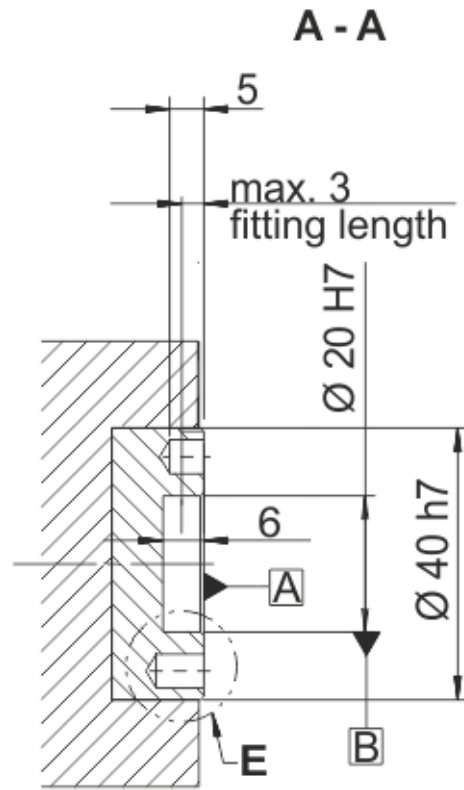
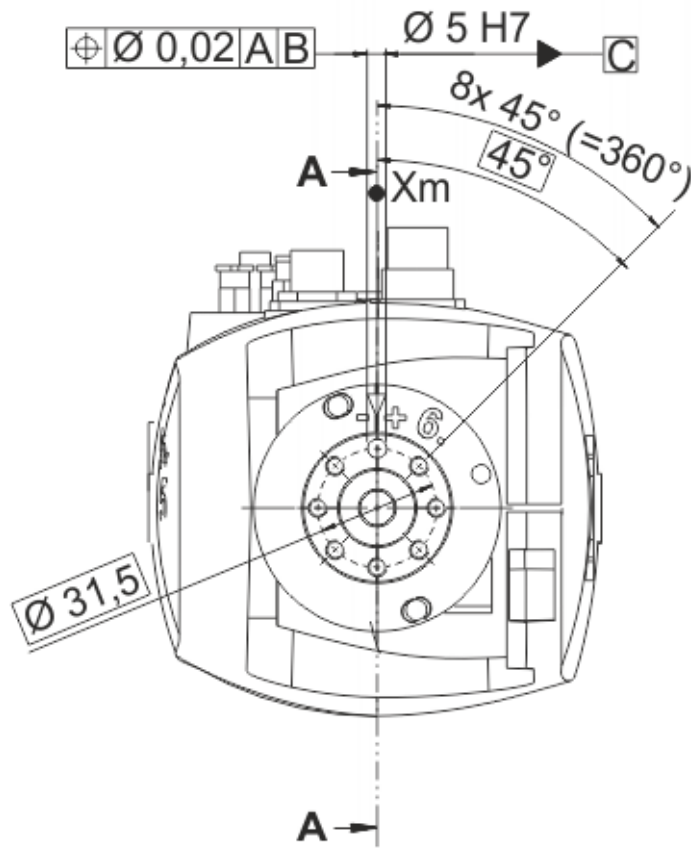

Detail E

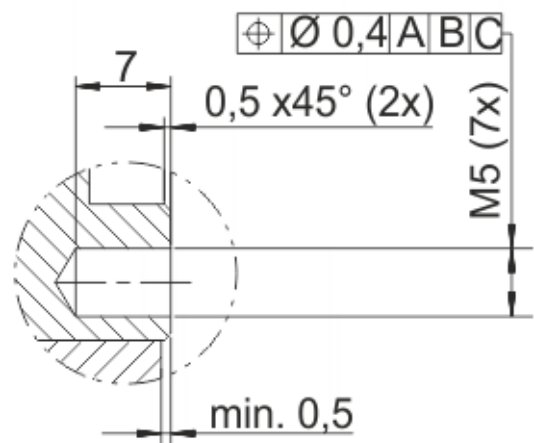

连接法兰

地基负载

地面安装位置时的地基负载	
F(v normal)	697 N
F(v max)	1297 N
F(h normal)	1223 N
F(h max)	1362 N
M(k normal)	788 Nm
M(k max)	1152 Nm
M(r normal)	367 Nm
M(r max)	880 Nm
天花板安装位置时的地基负载	
F(v normal)	697 N
F(v max)	1297 N
F(h normal)	1223 N
F(h max)	1362 N
M(k normal)	788 Nm
M(k max)	1152 Nm
M(r normal)	367 Nm
M(r max)	880 Nm
墙壁安装位置时的地基负载	
F(v normal)	697 N
F(v max)	1297 N
F(h normal)	1223 N
F(h max)	1362 N
M(k normal)	788 Nm
M(k max)	1152 Nm

M(r normal)	367 Nm
M(r max)	880 Nm

垂直力 $F(v)$ 、水平力 $F(h)$ 、倾斜力矩 $M(k)$ 、轴 1 的转矩 $M(r)$

Process forces

Process forces are forces that are exerted on the robot in a defined manner by an external influence. Causes include pressing processes and machining tasks carried out by the robot. The process forces that the robot can withstand depend to a very great degree on the robot position, payload, direction and duration of action. For this reason, it is not possible for a simple limit value to be specified for permissible process forces.

Permissible process torques are therefore specified for all axes of the robot. These values indicate the torque that each robot axis can withstand on a sustained basis as a result of external forces.

The following load torques must not be exceeded:

A1	200 Nm
A2	205 Nm
A3	135 Nm
A4	20 Nm
A5	20 Nm
A6	16 Nm

Flange loads

Flange loads

Due to the motion of the payload (e.g. tool) mounted on the robot, forces and torques act on the mounting flange. These forces and torques depend on the motion profile as well as the mass, load center of gravity and mass moment of inertia of the payload.

The specified values refer to nominal payloads at the nominal distance and do not include safety factors. It is imperative for the load data to be entered in the robot controller. The robot controller takes the payload into consideration during path planning. A reduced payload does not necessarily result in lower forces and torques.

The values are guide values determined by means of trial and simulation and refer to the most heavily loaded machine in the robot family. The actual forces and torques may differ due to internal and external influences on the mounting flange or a different point of application. It is therefore advisable to determine the exact forces and torques where necessary on site under the real conditions of the actual robot application.

The operating values may occur permanently in the normal motion profile. It is advisable to rate the tool for its fatigue strength.

The EMERGENCY STOP values may arise in the event of an Emergency Stop situation of the robot. As these should only occur very rarely during the service life of the robot, a static strength verification is usually sufficient.

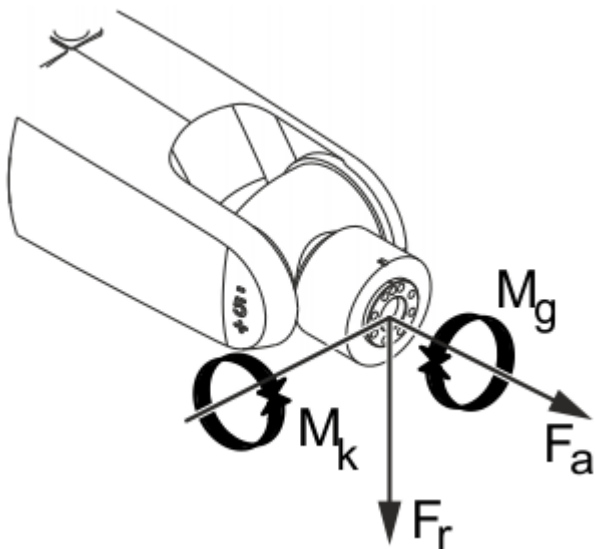

Flange loads

Flange loads during operation	
F(a)	399 N
F(r)	475 N

M(k)	49 Nm
M(g)	45 Nm
Flange loads in the case of EMERGENCY STOP	
F(a)	544 N
F(r)	669 N
M(k)	82 Nm
M(g)	113 Nm

Axial force $F(a)$, radial force $F(r)$, tilting torque $M(k)$, torque about mounting flange $M(g)$

轨迹精度

线性运动的轨迹精度:

LIN 轨迹绝对精度 (ISO 9283)	$\pm 1.6 \text{ mm}$
SLIN 轨迹绝对精度 (ISO 9283)	$\pm 0.9 \text{ mm}$
轨迹重复精度 线性 (ISO 9283)	$\pm 0.2 \text{ mm}$

该数据针对的是 0.8 m/s 的参考速度。

圆周运动的轨迹精度:

CIRC 轨迹绝对精度 (ISO 9283)	$\pm 1.2 \text{ mm}$
SCIRC 轨迹绝对精度 (ISO 9283)	$\pm 0.8 \text{ mm}$
圆周轨道重复精度 (ISO 9283)	$\pm 0.2 \text{ mm}$

该数据针对的是 0.4 m/s 的参考速度。

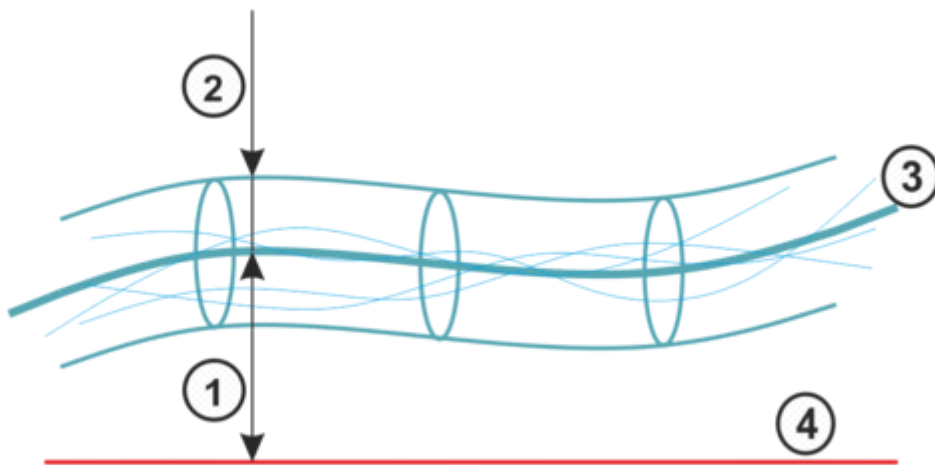

轨迹精度

1	轨迹绝对精度	3	运行轨迹的平均值
2	轨迹重复精度	4	编程的轨迹

- 轨迹精度表示机器人在编程的轨迹上运动的能力。
- 轨迹重复精度表示 10 个运行轨迹与运行轨迹平均值的偏差。

超调状态

振幅	0.3 mm
定位时间	0.2 s

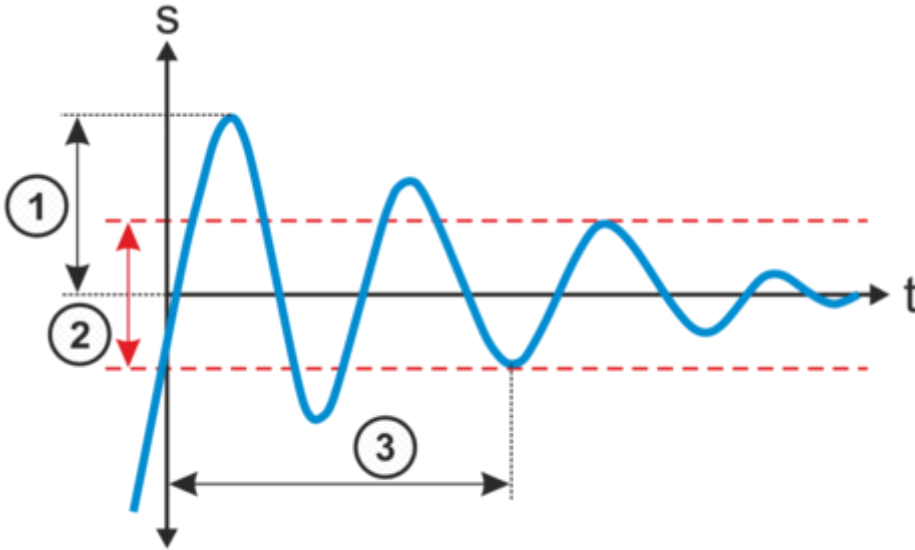

超调状态

1	超调振幅	3	定位时间
2	公差范围		

- 超调振幅影响机器人在特定位置执行受控的精确暂停的能力。
- 定位时间表示机器人在特定位置上停止的速度。

更多的信息

- 给出的数据基于 ISO 9283，并使用 Krypton/Metris 的基于摄像机的系统测得。因此重复精度被定义为 3 sigma 值。
- 所有数值均以额定负载测得。

关税信息

统计货号	84795000
原产地	DE
制造商	-
重量	52 kg

- > **KR 10 R900 CR** 需要 (11)
- > **KR 10 R900 CR** 带有如下的工具 (14)
- > **KR 10 R900 CR** 带有如下的备件 (18)
- > **KR 10 R900 CR** 有以下选项 (16)