

KUKA | Xpert

Identification number: AR23944

货号	0000-290-003
材料状态	10 - 批准预生产
制造商	KUKA Roboter
产品图片	

Spare parts

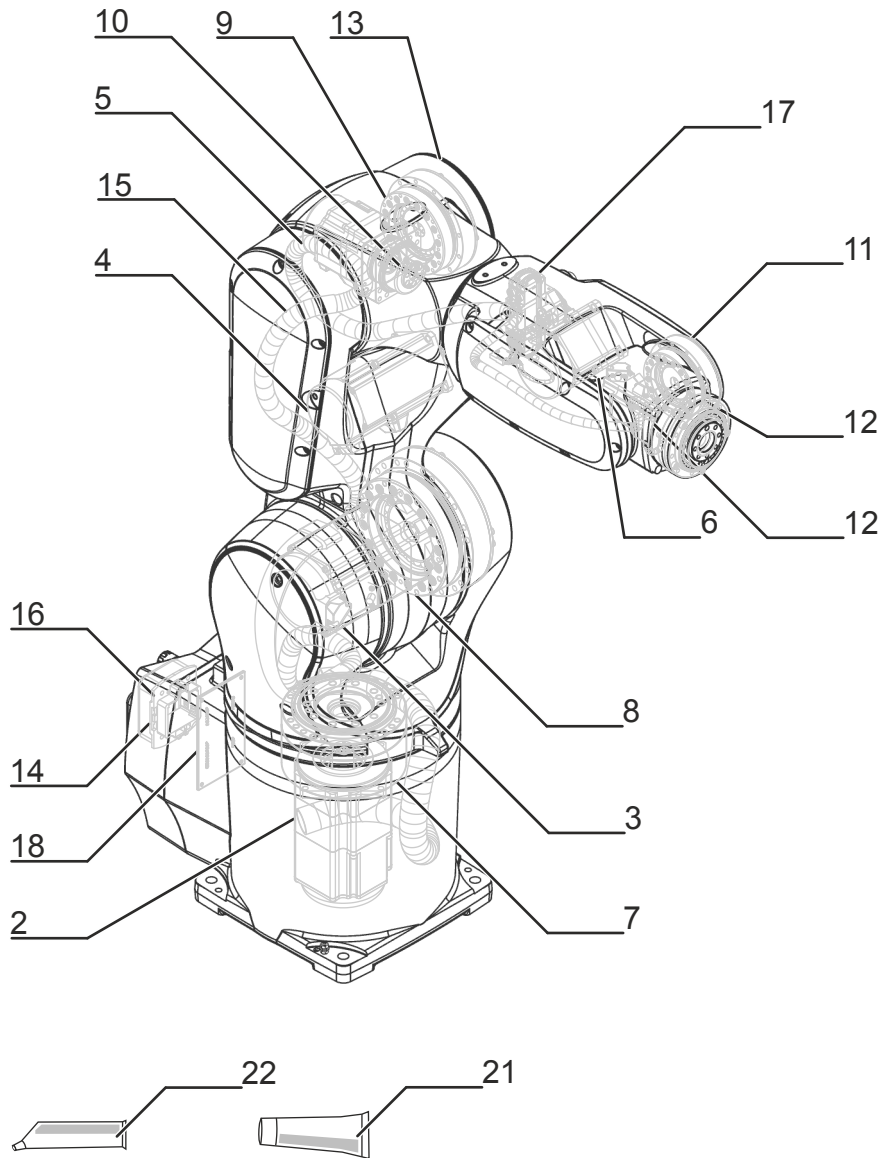

Spare parts graphic – schematic representation

Pos.	Article number	Designation	Component	Work instruction
1	0000-313-787	SPP set of toothed belts A3, A5 (KR 10)	Toothed belt	
2	0000-318-866	SPP motor A1	Motor A1	Exchanging motor A1
3	0000-313-666	SPP motor A2	Motor A2	Exchanging motor A2
4	0000-313-680	SPP motor A3	Motor A3	Exchanging motor A3
5	0000-318-867	SPP motor A4	Motor A4	

Pos.	Article number	Designation	Component	Work instruction
6	0000-313-674	SPP motor A5	Motor A5	Exchange motor A5
7	0000-318-915	SPP gear unit A1 (KR 10)	Gear A1	
8	0000-318-869	SPP gear unit A2 (KR 10)	Gear A2	
9	0000-318-870	SPP gear unit A3	Gear A3	
10	0000-318-885	SPP gear unit A4 (KR 10)	Gear A4	
11	0000-313-782	SPP gear unit A5 (KR10)	Gear A5	Exchanging gear unit A5
12	0000-313-752	SPP motor/gear unit A6 (KR10)	Gear A6 Motor A6	Exchanging motor/gear unit A6
13	0000-314-451	SPP belt-side cover (link arm, IW-GK)	Cover	
14	0000-313-760	SPP RDC (Agilus FL)	RDC	
15	0000-324-541	SPP cable set R1100 AIR CTR GIG*	Cable set	
	0000-324-542	SPP cable set R1100 AIR CTR*		
16	0000-313-761	SPP Electronic Data Storage (Agilus FL)	EDS	Exchanging the EDS
17	0000-291-642	Valve unit 2 assy		
18	0000-313-763	SPP I/O module (Agilus FL)		
19	0000-200-304	Mini gauge cartridge	Gauge cartridge	Exchanging gauge cartridges A1-6
20	0000-291-592	Connection unit 2 assy		
21	0000-271-296	Gear grease Harmonic Drive 4B No. 2	Lubricating grease	
22	0000-287-987	Cable grease Optitemp RB2 (0.4kg)	Cable grease	Checking and regreasing the cable set

Export to Excel 

Maintenance information

Toothed belt tension

Toothed belt tension motor	
A2	-
A3	160 ± 5 Hz
A4	-
A5	180 ± 5 Hz
A6	-

技术数据

基本数据

	KR 10 R1100-2
轴数	6
可控制的轴数	6
工作空间体积	5.2 m ³
位姿重复精度 (ISO 9283)	± 0.02 mm
重量	约 56.5 kg
额定负荷	5 kg
最大负载能力	11.1 kg
最大运动范围	1101 mm
防护等级 (IEC 60529)	IP65 / IP67
机器人腕部防护等级 (IEC 60529)	IP65 / IP67
噪声等级	< 57 dB (A)
安装位置	地面; 屋顶; 墙壁; 任意角度
占地面积	208 mm x 208 mm
运动系统安装面布孔图	C246
允许倾角	-
标准色	底座: 灰铝色 (RAL 9007); 活动部件: 交通白 (RAL 9016)
控制系统	KR C4 smallsize-2; KR C4 compact
变压器名称	KR C4: KR10R1100_2 C4SR

环境条件

湿度等级 (EN 60204)	-
环境条件分类 (EN 60721-3-3)	3K3
环境温度	
运行时	0 °C 至 45 °C (273 K 至 318 K)
仓储和运输时	-40 °C 至 60 °C (233 K 至 333 K)

轴数据

运动范围	
A1	±170 °
A2	-190 ° / 45 °
A3	-120 ° / 156 °
A4	±185 °
A5	±120 °
A6	±350 °
额定负载时的速度	
A1	300 °/s
A2	225 °/s
A3	330 °/s
A4	360 °/s
A5	360 °/s
A6	433 °/s

工作区域

KR 10 R1100-2 工作区域

负载能力

额定负荷	5 kg
最大负载能力	11.1 kg
法兰 lx 额定质量转动惯量	0.045 kgm ²
法兰 ly 额定质量转动惯量	0.045 kgm ²
法兰 lz 额定质量转动惯量	0.045 kgm ²
底座的额定附加负载	0 kg
底座的最大附加负载	0 kg
转盘的额定附加负载	0 kg
旋转机构的最大附加负载	1 kg
大臂的额定附加负载	0 kg
大臂的最大附加负载	1 kg
小臂的额定附加负载	0 kg
小臂的最大附加负载	2 kg
负载重心额定距离	
Lxy	100 mm
Lz	80 mm

Dimensions: mm

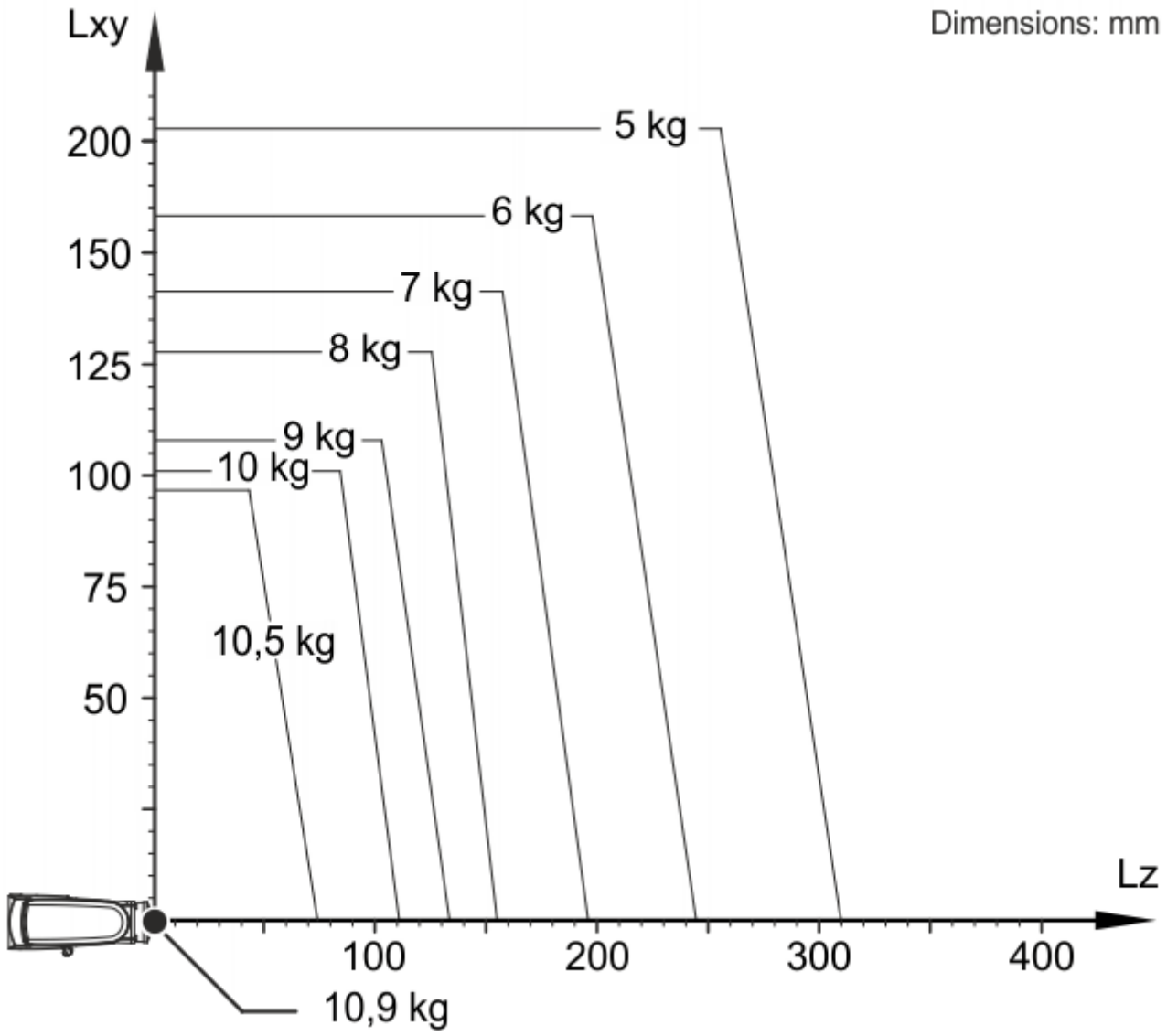

KR 10 R1100-2 负载能力图表

连接法兰

机器人腕部类型	ZH Arm KR10
连接法兰	见图纸

Dimensions: mm

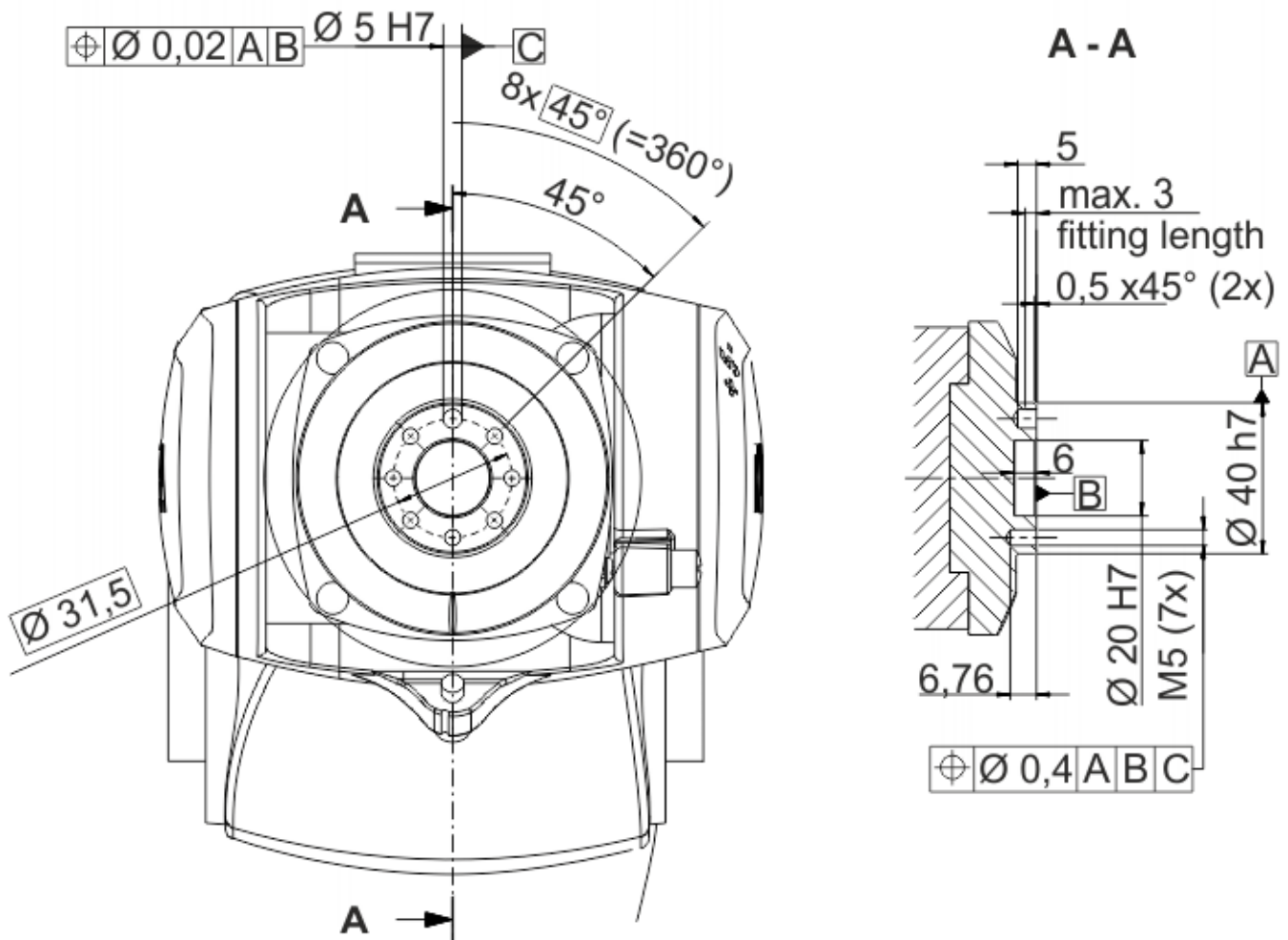

连接法兰

地基负载

地面安装位置时的地基负载	
F(v normal)	916 N
F(v max)	1200 N
F(h normal)	558 N
F(h max)	762 N
M(k normal)	542 Nm
M(k max)	894 Nm
M(r normal)	249 Nm
M(r max)	430 Nm
天花板安装位置时的地基负载	
F(v normal)	957 N
F(v max)	1156 N
F(h normal)	575 N
F(h max)	805 N
M(k normal)	574 Nm
M(k max)	913 Nm
M(r normal)	282 Nm
M(r max)	455 Nm
墙壁安装位置时的地基负载	
F(v normal)	1018 N
F(v max)	1172 N
F(h normal)	425 N
F(h max)	711 N
M(k normal)	688 Nm
M(k max)	1038 Nm

M(r normal)	280 Nm
M(r max)	420 Nm

垂直力 $F(v)$ 、水平力 $F(h)$ 、倾斜力矩 $M(k)$ 、轴 1 的转矩 $M(r)$

Process forces

Process forces are forces that are exerted on the robot in a defined manner by an external influence. Causes include pressing processes and machining tasks carried out by the robot. The process forces that the robot can withstand depend to a very great degree on the robot position, payload, direction and duration of action. For this reason, it is not possible for a simple limit value to be specified for permissible process forces.

Permissible process torques are therefore specified for all axes of the robot. These values indicate the torque that each robot axis can withstand on a sustained basis as a result of external forces.

The following load torques must not be exceeded:

A1	215 Nm
A2	230 Nm
A3	90 Nm
A4	22.5 Nm
A5	19 Nm
A6	9 Nm

Flange loads

Flange loads

Due to the motion of the payload (e.g. tool) mounted on the robot, forces and torques act on the mounting flange. These forces and torques depend on the motion profile as well as the mass, load center of gravity and mass moment of inertia of the payload.

The specified values refer to nominal payloads at the nominal distance and do not include safety factors. It is imperative for the load data to be entered in the robot controller. The robot controller takes the payload into consideration during path planning. A reduced payload does not necessarily result in lower forces and torques.

The values are guide values determined by means of trial and simulation and refer to the most heavily loaded machine in the robot family. The actual forces and torques may differ due to internal and external influences on the mounting flange or a different point of application. It is therefore advisable to determine the exact forces and torques where necessary on site under the real conditions of the actual robot application.

The operating values may occur permanently in the normal motion profile. It is advisable to rate the tool for its fatigue strength.

The EMERGENCY STOP values may arise in the event of an Emergency Stop situation of the robot. As these should only occur very rarely during the service life of the robot, a static strength verification is usually sufficient.

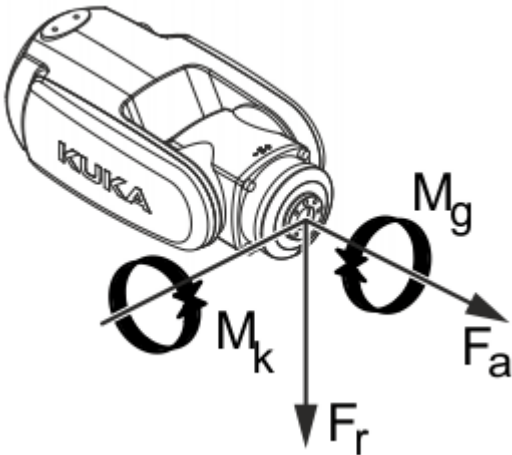

Flange loads

Flange loads during operation	
F(a)	289 N
F(r)	265 N
M(k)	34 Nm

M(g)	27 Nm
Flange loads in the case of EMERGENCY STOP	
F(a)	390 N
F(r)	407 N
M(k)	54 Nm
M(g)	42 Nm

Axial force $F(a)$, radial force $F(r)$, tilting torque $M(k)$, torque about mounting flange $M(g)$

精度数据

i 仅适用于带定位精确的机器人选项（用于地面或天花板安装）的机器人在地面位置测量的机器人只允许在地面位置运行。这同样适用于天花板位置的机器人。

位置精度

位置绝对精度 (ISO 9283)	$\pm 0.3 \text{ mm}$
位姿重复精度 (ISO 9283)	$\pm 0.02 \text{ mm}$

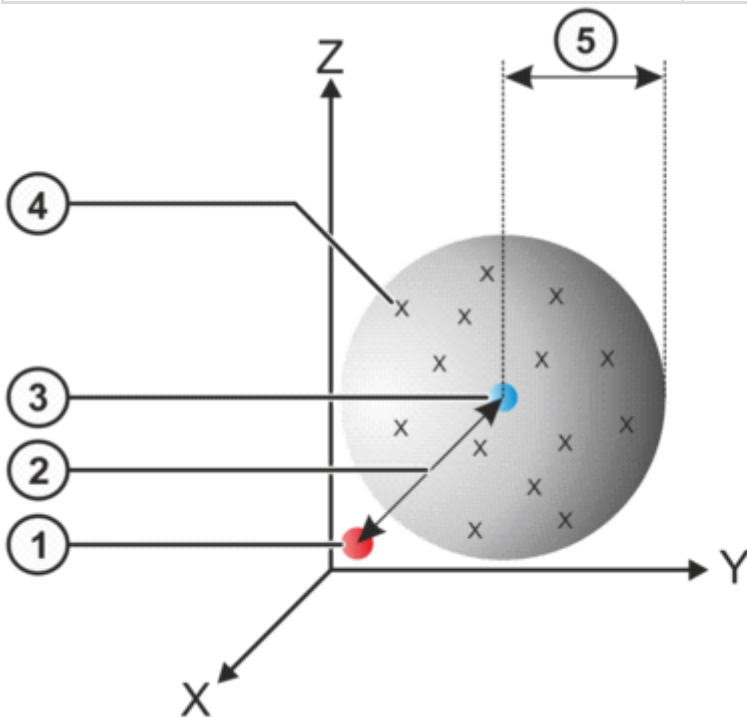

位置精度

1	编程设定的位置	4	测得的位置
2	位置绝对精度	5	位置重复精度
3	测得位置的平均值		

- 位置精度表示编程的机器人位置和实际占用的机器人位置之间的偏差，并用坐标测量机（CMM）在 9 个位置测量。
- 重复精度由重复 30 次测量时实际占用的机器人位置的偏差得出。
- 对于定位精确的机器人，这些值针对的是机器人基座。

轨迹精度

线性运动的轨迹精度:

LIN 轨迹绝对精度 (ISO 9283)	$\pm 0.4 \text{ mm}$
SLIN 轨迹绝对精度 (ISO 9283)	$\pm 0.8 \text{ mm}$
轨迹重复精度 线性 (ISO 9283)	$\pm 0.1 \text{ mm}$

该数据针对的是 0.8 m/s 的参考速度。

圆周运动的轨迹精度:

CIRC 轨迹绝对精度 (ISO 9283)	$\pm 0.55 \text{ mm}$
SCIRC 轨迹绝对精度 (ISO 9283)	$\pm 0.5 \text{ mm}$
圆周轨道重复精度 (ISO 9283)	$\pm 0.2 \text{ mm}$

该数据针对的是 0.4 m/s 的参考速度。

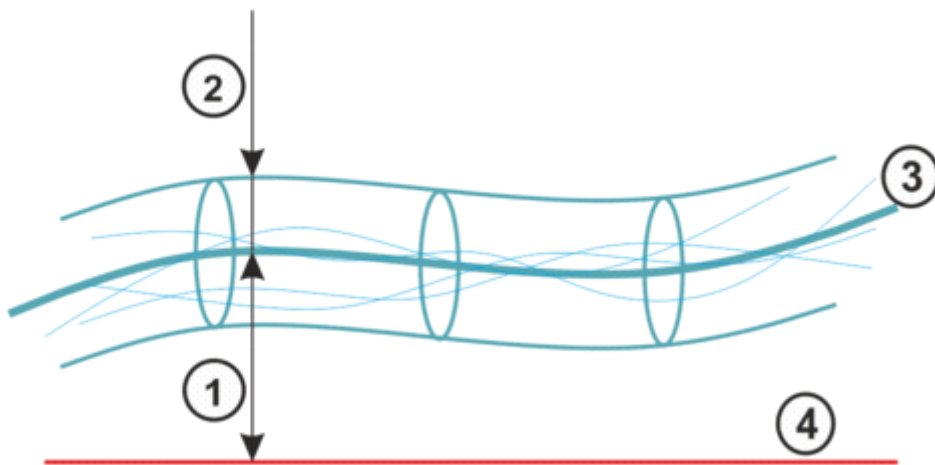

轨迹精度

1	轨迹绝对精度	3	运行轨迹的平均值
2	轨迹重复精度	4	编程的轨迹

- 轨迹精度表示机器人在编程的轨迹上运动的能力。
- 轨迹重复精度表示 10 个运行轨迹与运行轨迹平均值的偏差。

超调状态

振幅	1.21 mm
定位时间	0.53 s

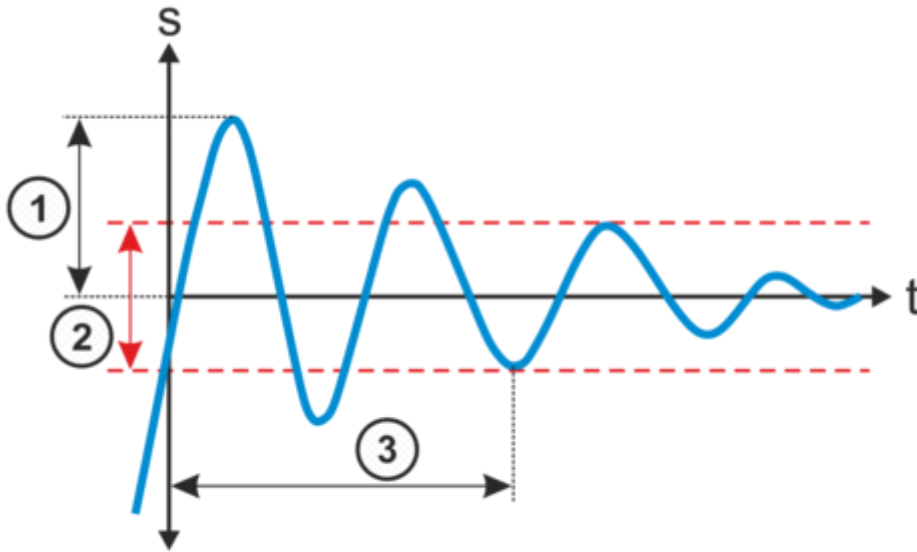

超调状态

1	超调振幅	3	定位时间
2	公差范围		

- 超调振幅影响机器人在特定位置执行受控的精确暂停的能力。
- 定位时间表示机器人在特定位置上停止的速度。

更多的信息

- 给出的数据基于 ISO 9283，并使用 Krypton/Metris 的基于摄像机的系统测得。因此重复精度被定义为 3 sigma 值。
- 所有数值均以额定负载测得。

关税信息

统计货号	84795000
原产地	DE
制造商	-
重量	55 kg

- > **KR 10 R1100-2** 需要 (5)
- > **KR 10 R1100-2** 带有如下的工具 (13)
- > **KR 10 R1100-2** 带有如下的备件 (18)
- > **KR 10 R1100-2** 有以下选项 (42)