

KUKA | Xpert

Identification number: AR8548

货号	0000-255-270
材料状态	60 - 客户服务
制造商	KUKA Roboter
产品图片	

Spare parts

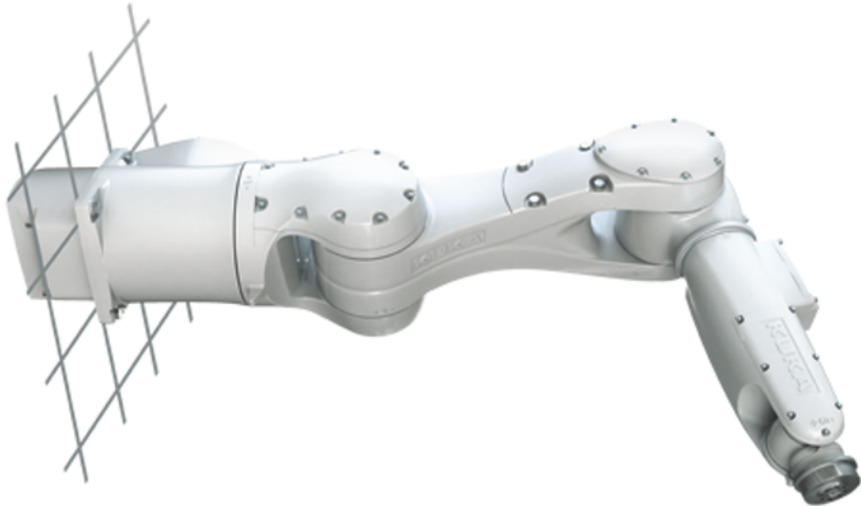
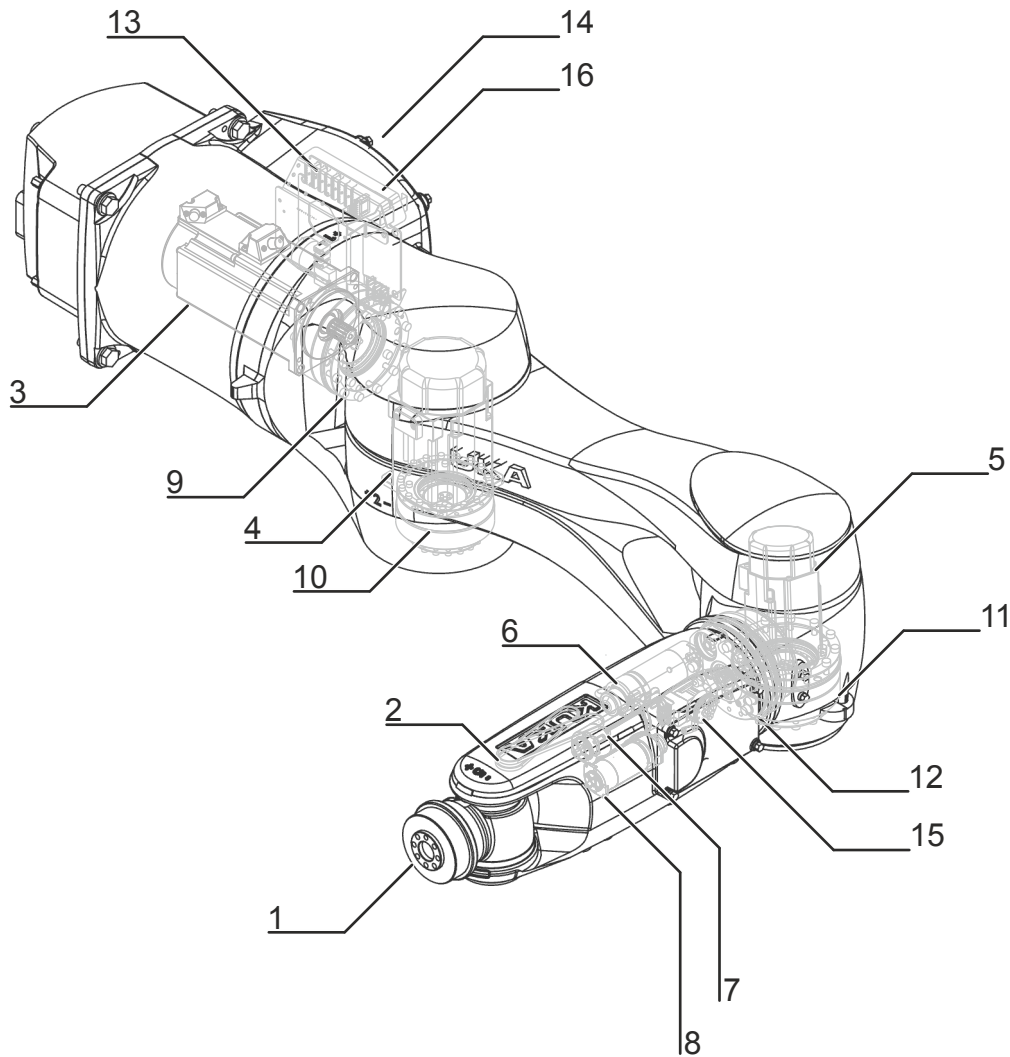

Spare parts graphic – schematic representation

Pos.	Article number	Designation	Component
1	0000-285-269	SPP sw.hous. A6 HM (w/o gr/ad) KR6 R700	In-line wrist
2	0000-285-270	SPP wrist, set of belts, IW6 R700 HM	Toothed belt
3	0000-252-708	SPP Motor A1 HM (without grease)	Motor A1

Pos.	Article number	Designation	Component
4	0000-256-591	SPP Motor A2 HM (wgg)	Motor A2
5	0000-256-592	SPP Motor A3 HM (wgg)	Motor A3
6	0000-285-263	SPP motor A4 HM (w/o gr/ad) R700	Motor A4
7	0000-285-264	SPP motor A5 HM R700	Motor A5
8	0000-285-267	SPP motor A6 HM R700	Motor A6
9	0000-252-709	SSP gear A1 HM; KR6 (wgg)	Gear A1
10	0000-252-710	SPP gear A2 HM; KR6 (wgg)	Gear A2
11	0000-252-711	SPP gear A3 HM; KR6 (wgg)	Gear A3
12	0000-285-268	SPP wrist, gear unit A4 HM (w/o g/a)R700	Gear A4
13	0000-284-202	SPP RDC cool HM (Agilus)	RDC
14	0000-284-204	SPP EDS cool HM (Agilus)	EDS
15	0000-284-704	SPP valve unit assy HM (w/o gr/ad)	
16	0000-284-205	SPP I/O module cool HM (Agilus)	
17	0000-284-206	SPP connecting cable HM (Agilus)	
18	0000-200-304	Mini gauge cartridge	Gauge cartridge
19	0000-203-379	Needle bearing w/o inner ring 139x145x17	
20	0000-203-381	Needle bearing w/o inner ring 118x123x10	

Export to Excel 

Maintenance information

Toothed belt tension

Toothed belt tension inline wrist	
A5	305 ± 5 Hz
A6	305 ± 5 Hz

技术数据

基本数据

	KR 6 R700 sixx W-HM-SC
轴数	6
可控制的轴数	6
工作空间体积	1.3 m ³
位姿重复精度 (ISO 9283)	± 0.03 mm
重量	约 60 kg
额定负荷	3 kg
最大运动范围	706.7 mm
防护等级 (IEC 60529)	IP65 / IP67
机器人腕部防护等级 (IEC 60529)	IP65 / IP67
噪声等级	< 70 dB (A)
安装位置	墙壁
占地面积	320 mm x 320 mm
运动系统安装面布孔图	C246
允许倾角	-
标准色	底座： 交通白 (RAL 9016); 活动部件： 交通白 (RAL 9016)
控制系统	KR C4 smallsize-2; KR C4 compact
变压器名称	KR C4: KR6R700 HM C4SR

环境条件

湿度等级 (EN 60204)	-
环境条件分类 (EN 60721-3-3)	3B2; 3Z10
环境温度	
运行时	0 °C 至 35 °C (273 K 至 308 K)
仓储和运输时	-40 °C 至 60 °C (233 K 至 333 K)

轴参数

运动范围	
A1	$\pm 166^\circ$
A2	$-188^\circ / 45^\circ$
A3	$-115^\circ / 144^\circ$
A4	$\pm 185^\circ$
A5	$\pm 110^\circ$
A6	$\pm 350^\circ$
额定负载时的速度	
A1	360 °/s
A2	300 °/s
A3	360 °/s
A4	381 °/s
A5	327 °/s
A6	518 °/s

负载能力

额定负荷	3 kg
最大负载能力	6 kg
法兰 Ix 额定质量转动惯量	0.045 kgm ²
底座的额定附加负载	0 kg
底座的额定最大附加负载	-
转盘的额定附加负载	0 kg
旋转机构的最大附加负载	1 kg
大臂的额定附加负载	0 kg
大臂的额定最大附加负载	1 kg
小臂的额定附加负载	0 kg
小臂的额定最大附加负载	2 kg
最大总负载	6 kg
负载重心额定距离	
Lxy	60 mm
Lz	80 mm

地基负载

纵向动力 F(v)	
F(v 正常)	415 N
F(vmax)	775 N
横向动力 F(h)	
F(h 正常)	1125 N
F(hmax)	1488 N
倾覆力矩 M(k)	
M(k 正常)	742 Nm
M(kmax)	1142 Nm
轴 2 转矩 M(r)	
M(r 正常)	307 Nm
M(rmax)	654 Nm

垂直力 $F(v)$ 、水平力 $F(h)$ 、倾斜力矩 $M(k)$ 、轴 1 的转矩 $M(r)$

Flange loads

Flange loads

Due to the motion of the payload (e.g. tool) mounted on the robot, forces and torques act on the mounting flange. These forces and torques depend on the motion profile as well as the mass, load center of gravity and mass moment of inertia of the payload.

The specified values refer to nominal payloads at the nominal distance and do not include safety factors. It is imperative for the load data to be entered in the robot controller. The robot controller takes the payload into consideration during path planning. A reduced payload does not necessarily result in lower forces and torques.

The values are guide values determined by means of trial and simulation and refer to the most heavily loaded machine in the robot family. The actual forces and torques may differ due to internal and external influences on the mounting flange or a different point of application. It is therefore advisable to determine the exact forces and torques where necessary on site under the real conditions of the actual robot application.

The operating values may occur permanently in the normal motion profile. It is advisable to rate the tool for its fatigue strength.

The EMERGENCY STOP values may arise in the event of an Emergency Stop situation of the robot. As these should only occur very rarely during the service life of the robot, a static strength verification is usually sufficient.

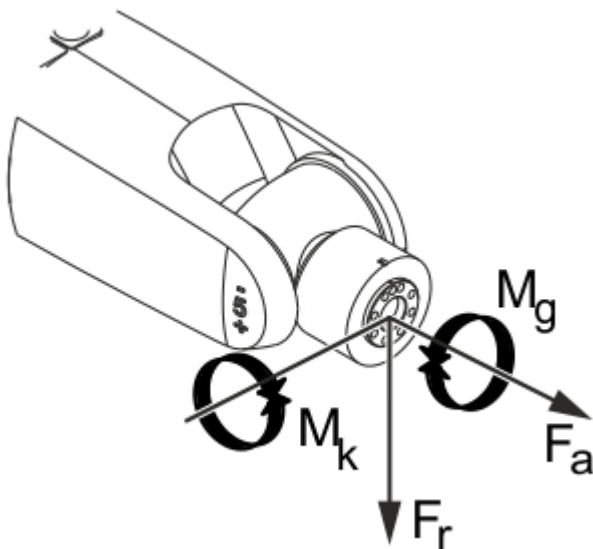

Flange loads

Flange loads during operation	
F(a)	187 N
F(r)	318 N

M(k)	29 Nm
M(g)	25 Nm
Flange loads in the case of EMERGENCY STOP	
F(a)	412 N
F(r)	524 N
M(k)	65 Nm
M(g)	51 Nm

Axial force $F(a)$, radial force $F(r)$, tilting torque $M(k)$, torque about mounting flange $M(g)$

关税信息

统计货号	84795000
原产地	DE
制造商	-
重量	60 kg

-
- > **KR 6 R700 sixx W-HM-SC** 带有如下的工具 (13)
 - > **KR 6 R700 sixx W-HM-SC** 有以下选项 (16)
 - > **KR 6 R700 sixx W-HM-SC** 带有如下的标准组件 (1)
 - > **KR 6 R700 sixx W-HM-SC** 需要 (6)
 - > **KR 6 R700 sixx W-HM-SC** 带有如下的备件 (18)