

KUKA | Xpert

Identification number: AR5756

货号	0000-143-407
材料状态	10 - 批准预生产
制造商	KUKA Roboter
产品图片	

Spare parts

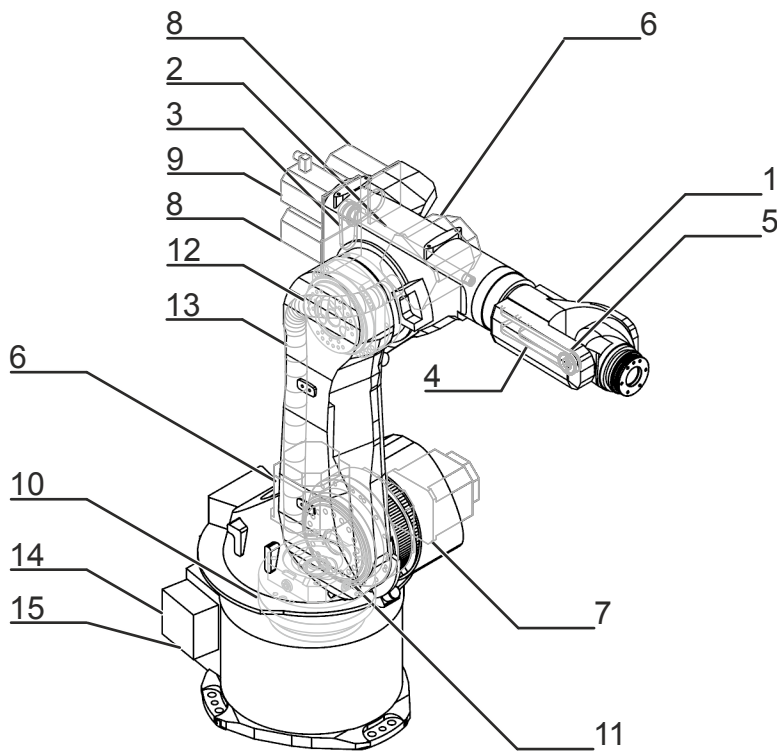

Spare parts graphic KR 60 L30-4 KS , schematic representation

Pos.	Article number	Designation	Component
1	0000-253-375	SPP IW 30/45/60 III	In-line wrist
2	0000-110-827	Set of shafts KR60L30/2	Connecting shaft
3	0063-122-169	Toothed belt	Toothed belt A4
4	0071-053-329	Toothed belt Synchrofl. 10 AT 5/780-5/8	Toothed belt A5
5	0071-053-328	Toothed belt Synchrofl. 12 AT 5/920-5/8	Toothed belt A6
6	0000-117-606	ME 180 180 40 S0	Motor A1 Motor A3
7	0000-119-766	ME 228 180 30 S0	Motor A2
8	0000-117-746	Wrist axis drive TYPE-D0/1FK7060	Motor A4 Motor A5
9	0000-115-926	ME 60 110 30 S0	Motor A6

Pos.	Article number	Designation	Component
10	0000-143-388	Gear unit RV-320EL-170	Gear A1
11	0000-142-756	Gear unit RV-320E -171	Gear A2
12	0000-128-111	Gear unit RV-320E-141	Gear A3
13	0000-199-868	KRC4 robot cable set assy KR30/3KS	Cable set
	0000-132-258	Standard cable set with RDC, KR 30KS	
	0000-139-780	Safe cable set assy, KR 30KS	
14	0000-246-872	Resolver Digital Converter RDC	RDC
15	0000-172-903	Electronic Data Storage EDS	EDS
16	0000-119-966	RDC 2 Resolver Digital Converter 120MHz	
17	0000-194-084	Safe RDC w. I/O print spare part	

Export to Excel 

Maintenance information

Gear oil



The quantity of oil drained depends on the draining time and the oil temperature. The refilling quantity is the quantity of oil that was drained from the gear unit at the correct operating temperature and with the correct draining time. This oil quantity must be determined. Only this quantity of oil may be used when refilling.

If less than 70 % of the specified oil quantity flows out, flush the gear unit with the determined quantity of drained oil once, then pour in the amount of oil that was drained. If less than 50% of the specified oil quantity flows out (e.g. inclined installation), the flushing operation must be repeated twice. During the flushing procedure, move the axis at jog velocity throughout the entire axis range.

The oil quantities specified in the table correspond to the oil quantities in the gear unit at first filling.

Gear oil new filling quantity	
A1	3.30 l
A2	1.00 l
A3	1.00 l
A4	0.55 l
A5 / A6	0.75 l
Gear oil refilling quantity	
A1	1.70 l
A2	0.90 l
A3	0.90 l
A4	0.55 l
A5 / A6	0.75 l

Toothed belt tension

Toothed belt tension motor	
A4	95 ± 2 Hz
A5	95 ± 2 Hz
A6	-
Toothed belt tension inline wrist	
A5	130 ± 5 Hz
A6	185 ± 5 Hz

技术数据

基本数据

	KR 60 L30-4 KS
轴数	6
可控制的轴数	6
工作空间体积	47.9 m ³
位姿重复精度 (ISO 9283)	± 0.06 mm
重量	约 615 kg
额定负荷	30 kg
最大负载能力	-
最大运动范围	2628 mm
防护等级 (IEC 60529)	IP64
机器人腕部防护等级 (IEC 60529)	IP65
噪声等级	< 75 dB (A)
安装位置	地面
占地面积	972 mm x 826 mm
运动系统安装面布孔图	-
允许倾角	≤ 5 °
标准色	底座： 黑色 (RAL 9005); 活动部件： 库卡橙色 2567
控制系统	KR C4
变压器名称	KR C4: KR60L30KLB_4 C4 FLR ZH02

环境条件

湿度等级 (EN 60204)	-
环境条件分类 (EN 60721-3-3)	3K3
环境温度	
运行时	10 °C 至 55 °C (283 K 至 328 K)
仓储和运输时	-40 °C 至 60 °C (233 K 至 333 K)

轴数据

运动范围	
A1	±150 °
A2	-105 ° / 75 °
A3	-120 ° / 158 °
A4	±350 °
A5	±119 °
A6	±350 °
额定负载时的速度	
A1	138 °/s
A2	130 °/s
A3	166 °/s
A4	260 °/s
A5	245 °/s
A6	322 °/s

负载能力

额定负荷	30 kg
最大负载能力	-
法兰 I_x 额定质量转动惯量	9 kgm ²
法兰 I_y 额定质量转动惯量	9 kgm ²
法兰 I_z 额定质量转动惯量	9 kgm ²
底座的额定附加负载	0 kg
底座的最大附加负载	-
转盘的额定附加负载	0 kg
旋转机构的最大附加负载	0 kg
大臂的额定附加负载	0 kg
大臂的最大附加负载	0 kg
小臂的额定附加负载	35 kg
小臂的最大附加负载	35 kg
负载重心额定距离	
L_{xy}	180 mm
L_z	150 mm

地基负载

纵向动力 F(v)	
F(v 正常)	8100 N
F(vmax)	10850 N
横向动力 F(h)	
F(h 正常)	6250 N
F(hmax)	9550 N
倾覆力矩 M(k)	
M(k 正常)	8400 Nm
M(kmax)	14150 Nm
轴 2 转矩 M(r)	
M(r 正常)	4100 Nm
M(rmax)	12850 Nm

垂直力 $F(v)$ 、水平力 $F(h)$ 、倾斜力矩 $M(k)$ 、轴 1 的转矩 $M(r)$

关税信息

统计货号	84795000
原产地	DE
制造商	KUKA ROBOTER
重量	665 kg

-
- > **KR 60 L30-4 KS** 带有如下的工具 (6)
 - > **KR 60 L30-4 KS** 有以下选项 (13)
 - > **KR 60 L30-4 KS** 带有如下的标准组件 (4)
 - > **KR 60 L30-4 KS** 需要 (22)
 - > **KR 60 L30-4 KS** 带有如下的备件 (18)