

KUKA | Xpert

Identification number: AR6202

货号	0000-128-455
材料状态	40 - 停产
制造商	KUKA Roboter
产品图片	

Spare parts

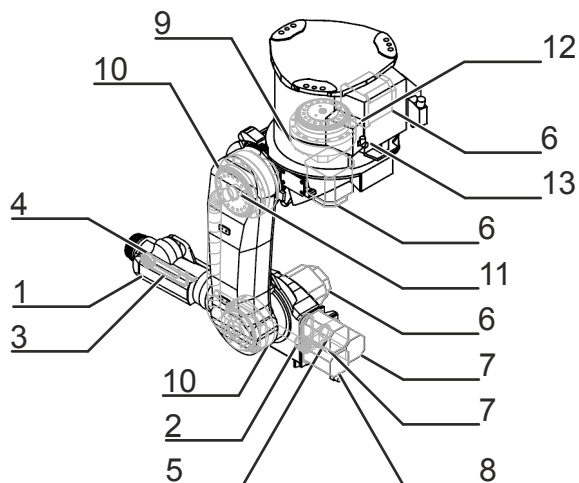

Spare parts graphic KR 30-3 C , schematic representation

Pos.	Article number	Designation	Component
1	0000-253-375	SPP IW 30/45/60 III	In-line wrist
2	0000-110-696	Set of shafts KR30/45/60/2	Connecting shaft
3	0071-053-328	Toothed belt Synchrofl. 12 AT 5/920-5/8	Toothed belt A6
4	0071-053-329	Toothed belt Synchrofl. 10 AT 5/780-5/8	Toothed belt A5
5	0063-122-169	Toothed belt	Toothed belt A4
6	0000-117-606	ME 180 180 40 S0	Motor A1 Motor A2 Motor A3
7	0000-117-746	Wrist axis drive TYPE-D0/1FK7060	Motor A4 Motor A5
8	0000-115-926	ME 60 110 30 S0	Motor A6
9	0071-050-782	Gear unit RV-320EL-184	Gear A1
10	0000-264-429	Preassembly of gear unit RV-320E-185	Gear A2 Gear A3
11	0000-183-748	KRC4 robot cable set assy KR30/60-3	Cable set

Pos.	Article number	Designation	Component
12	0000-246-872	Resolver Digital Converter RDC	RDC
13	0000-172-903	Electronic Data Storage EDS	EDS

Export to Excel 

Maintenance information

Gear oil

CAUTION

The quantity of oil drained depends on the draining time and the oil temperature. The refilling quantity is the quantity of oil that was drained from the gear unit at the correct operating temperature and with the correct draining time. This oil quantity must be determined. Only this quantity of oil may be used when refilling.

If less than 70 % of the specified oil quantity flows out, flush the gear unit with the determined quantity of drained oil once, then pour in the amount of oil that was drained. If less than 50% of the specified oil quantity flows out (e.g. inclined installation), the flushing operation must be repeated twice. During the flushing procedure, move the axis at jog velocity throughout the entire axis range.

The oil quantities specified in the table correspond to the oil quantities in the gear unit at first filling.

Gear oil new filling quantity	
A1	3.30 l
A2	1.00 l
A3	1.00 l
A4	0.55 l
A5 / A6	0.75 l
Gear oil refilling quantity	
A1	1.70 l
A2	0.90 l
A3	0.90 l
A4	0.55 l
A5 / A6	0.75 l

Toothed belt tension

Toothed belt tension motor	
A4	95 ± 2 Hz
A5	95 ± 2 Hz
A6	-
Toothed belt tension inline wrist	
A5	130 ± 5 Hz
A6	185 ± 5 Hz

技术数据

基本数据

	KR 30-3 C
轴数	6
可控制的轴数	6
工作空间体积	27.2 m ³
位姿重复精度 (ISO 9283)	± 0.06 mm
重量	约 635 kg
额定负荷	30 kg
最大负载能力	-
最大运动范围	2033 mm
防护等级 (IEC 60529)	IP64
机器人腕部防护等级 (IEC 60529)	IP65
噪声等级	< 75 dB (A)
安装位置	屋顶
占地面积	660 mm x 660 mm
运动系统安装面布孔图	-
允许倾角	-
标准色	底座： 黑色 (RAL 9005); 活动部件： 库卡橙色 2567
控制系统	KR C4
变压器名称	KR C4: KR30_3 C4 CLG ZH02

环境条件

湿度等级 (EN 60204)	-
环境条件分类 (EN 60721-3-3)	3K3
环境温度	
运行时	10 °C 至 55 °C (283 K 至 328 K)
仓储和运输时	-40 °C 至 60 °C (233 K 至 333 K)

轴数据

运动范围	
A1	±185 °
A2	-135 ° / 35 °
A3	-120 ° / 158 °
A4	±350 °
A5	±119 °
A6	±350 °
额定负载时的速度	
A1	140 °/s
A2	126 °/s
A3	140 °/s
A4	260 °/s
A5	245 °/s
A6	322 °/s

负载能力

额定负荷	30 kg
最大负载能力	-
法兰 lx 额定质量转动惯量	9 kgm ²
法兰 ly 额定质量转动惯量	9 kgm ²
法兰 lz 额定质量转动惯量	9 kgm ²
底座的额定附加负载	0 kg
底座的最大附加负载	-
转盘的额定附加负载	0 kg
旋转机构的最大附加负载	0 kg
大臂的额定附加负载	0 kg
大臂的最大附加负载	0 kg
小臂的额定附加负载	35 kg
小臂的最大附加负载	35 kg
负载重心额定距离	
Lxy	180 mm
Lz	150 mm

地基负载

纵向动力 $F(v)$	
$F(v)$ 正常)	9000 N
$F(v_{max})$	13600 N
横向动力 $F(h)$	
$F(h)$ 正常)	6950 N
$F(h_{max})$	12300 N
倾覆力矩 $M(k)$	
$M(k)$ 正常)	11900 Nm
$M(k_{max})$	21600 Nm
轴 2 转矩 $M(r)$	
$M(r)$ 正常)	6850 Nm
$M(r_{max})$	18400 Nm

垂直力 $F(v)$ 、水平力 $F(h)$ 、倾斜力矩 $M(k)$ 、轴 1 的转矩 $M(r)$

Process forces

Process forces are forces that are exerted on the robot in a defined manner by an external influence. Causes include pressing processes and machining tasks carried out by the robot. The process forces that the robot can withstand depend to a very great degree on the robot position, payload, direction and duration of action. For this reason, it is not possible for a simple limit value to be specified for permissible process forces.

Permissible process torques are therefore specified for all axes of the robot. These values indicate the torque that each robot axis can withstand on a sustained basis as a result of external forces.

The following load torques must not be exceeded:

A1	-
A2	-
A3	-
A4	270 Nm
A5	260 Nm
A6	200 Nm

Flange loads

Flange loads

Due to the motion of the payload (e.g. tool) mounted on the robot, forces and torques act on the mounting flange. These forces and torques depend on the motion profile as well as the mass, load center of gravity and mass moment of inertia of the payload.

The specified values refer to nominal payloads at the nominal distance and do not include safety factors. It is imperative for the load data to be entered in the robot controller. The robot controller takes the payload into consideration during path planning. A reduced payload does not necessarily result in lower forces and torques.

The values are guide values determined by means of trial and simulation and refer to the most heavily loaded machine in the robot family. The actual forces and torques may differ due to internal and external influences on the mounting flange or a different point of application. It is therefore advisable to determine the exact forces and torques where necessary on site under the real conditions of the actual robot application.

The operating values may occur permanently in the normal motion profile. It is advisable to rate the tool for its fatigue strength.

The EMERGENCY STOP values may arise in the event of an Emergency Stop situation of the robot. As these should only occur very rarely during the service life of the robot, a static strength verification is usually sufficient.

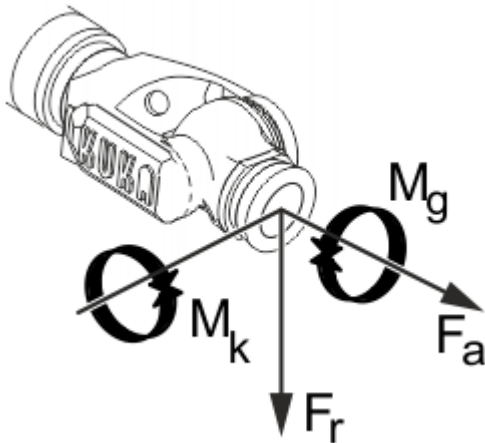

Flange loads

Flange loads during operation	
F(a)	1390 N
F(r)	970 N
M(k)	230 Nm

M(g)	200 Nm
Flange loads in the case of EMERGENCY STOP	
F(a)	1400 N
F(r)	2190 N
M(k)	440 Nm
M(g)	330 Nm

Axial force $F(a)$, radial force $F(r)$, tilting torque $M(k)$, torque about mounting flange $M(g)$

关税信息

统计货号	84795000
原产地	DE
制造商	KUKA ROBOTER
重量	665 kg

- > **KR 30-3 C** 带有如下的工具 (6)
- > **KR 30-3 C** 有以下选项 (38)
- > **KR 30-3 C** 带有如下的标准组件 (4)
- > **KR 30-3 C** 需要 (22)
- > **KR 30-3 C** 带有如下的备件 (13)