

KUKA | Xpert

Identification number: AR9187

货号	0000-262-128
材料状态	60 - 客户服务
制造商	KUKA Roboter
产品图片	

Spare parts

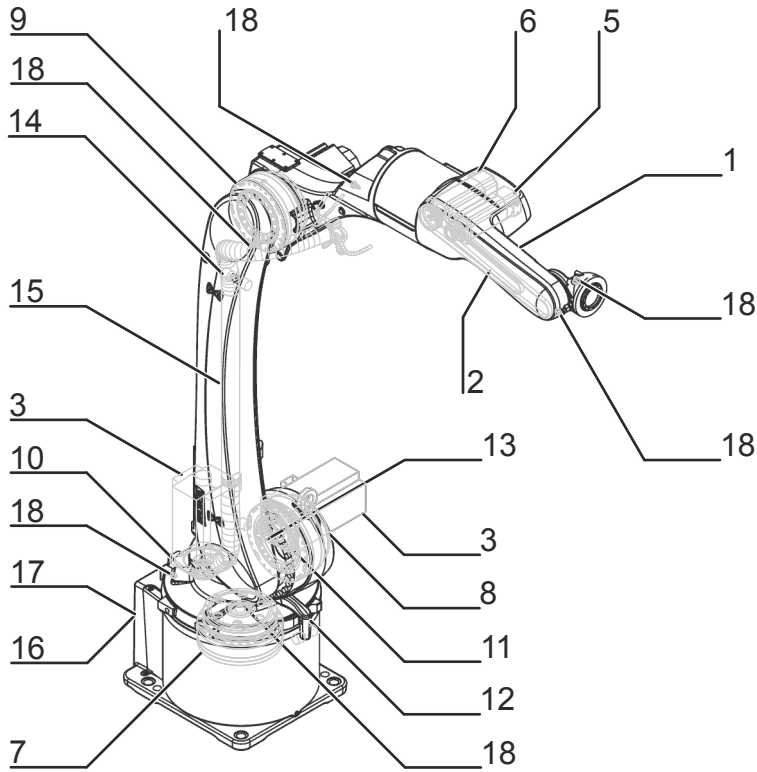

Spare parts graphic KR 8 R2100 arc HW , schematic representation

Pos.	Article number	Designation	Component	Work instruction
1	0000-292-356	SPP In-line wrist 8 HW	In-line wrist	
2	0000-256-713	SPP set of belts A5/A6 HW	Toothed belt	Exchanging toothed belt on A5 and A6
3	0000-292-256	SPP motor 2.0kW ME	Motor A1 Motor A2	Exchanging motor A1 更换轴 A2 的电机
4	0000-349-341	SPP motor 1.8kW ME		更换轴 A3 的电机
5	0000-256-712	SPP motor A5 HW	Motor A5	Exchanging motor A5
6	0000-256-715	SPP motor A6 HW	Motor A6	Exchanging motor A6
7	0000-292-675	SPP gear unit A1 i=55; z=64	Gear A1	Exchanging gear unit A1
8	0000-292-260	SPP gear unit TS225 PS i=167 (w/o oil)	Gear A2	Exchanging gear unit A2

Pos.	Article number	Designation	Component	Work instruction
9	0000-292-261	SPP gear unit TS185-G i=117	Gear A3	Exchanging gear unit A3
10	0000-292-263	SPP input stage TS225 PS i=125	Input gear stage A1	
11	0000-292-262	SPP input stage TS225 PS i=167	Input gear stage A2	Exchanging gear unit A2
12	0000-268-767	Axis limit A1 15°	Range limitation A1	
13	0000-265-974	Axis limit A2 15°	Range limitation A2	
14	0000-268-896	Axis limit A3 12°	Range limitation A3	
15	0000-279-575	Cable set INT 076HW2100	Cable set	Exchanging the cable set
16	0000-246-872	Resolver Digital Converter RDC	RDC	Exchanging the RDC
17	0000-172-903	Electronic Data Storage EDS	EDS	Exchanging the EDS
18	0000-200-304	Mini gauge cartridge	Mastering cartridge A1 Mastering cartridge A2 Mastering cartridge A3 Mastering cartridge A4 Mastering cartridge A5 Mastering cartridge A6	

Export to Excel 

Maintenance information

Gear oil



The quantity of oil drained depends on the draining time and the oil temperature. The refilling quantity is the quantity of oil that was drained from the gear unit at the correct operating temperature and with the correct draining time. This oil quantity must be determined. Only this quantity of oil may be used when refilling.

If less than 70 % of the specified oil quantity flows out, flush the gear unit with the determined quantity of drained oil once, then pour in the amount of oil that was drained. If less than 50% of the specified oil quantity flows out (e.g. inclined installation), the flushing operation must be repeated twice. During the flushing procedure, move the axis at jog velocity throughout the entire axis range.

The oil quantities specified in the table correspond to the oil quantities in the gear unit at first filling.

Gear oil new filling quantity	
A1	1.20 l
A2	0.80 l
A3	0.32 l
A4	0.08 l
A5 / A6	0.07 l
Gear oil refilling quantity	
A1	1.00 l
A2	0.77 l
A3	0.30 l
A4	-
A5 / A6	-

Toothed belt tension

Toothed belt tension inline wrist	
A5	110 ± 5 Hz
A6	60 ± 5 Hz

技术数据

基本数据

	KR 8 R2100 arc HW
轴数	6
可控制的轴数	6
工作空间体积	36.58 m ³
位姿重复精度 (ISO 9283)	± 0.04 mm
重量	约 255 kg
额定负荷	8 kg
最大负载能力	-
最大运动范围	2101 mm
防护等级 (IEC 60529)	IP65
机器人腕部防护等级 (IEC 60529)	IP54
噪声等级	< 75 dB (A)
安装位置	地面; 屋顶; 墙壁; 任意角度
占地面积	430.5 mm x 370 mm
运动系统安装面布孔图	S260
允许倾角	-
标准色	底座: 黑色 (RAL 9005); 活动部件: 库卡橙色 2567
控制系统	KR C4
变压器名称	KR C4: KR8R2100 arc HW C4

环境条件

湿度等级 (EN 60204)	-
环境条件分类 (EN 60721-3-3)	3K3
环境温度	
运行时	5 °C 至 45 °C (278 K 至 318 K)
仓储和运输时	-20 °C 至 60 °C (253 K 至 333 K)

轴数据

运动范围	
A1	±185 °
A2	-185 ° / 65 °
A3	-138 ° / 175 °
A4	±165 °
A5	-115 ° / 140 °
A6	±350 °
额定负载时的速度	
A1	200 °/s
A2	175 °/s
A3	190 °/s
A4	430 °/s
A5	430 °/s
A6	630 °/s

工作区域

Dimensions: mm

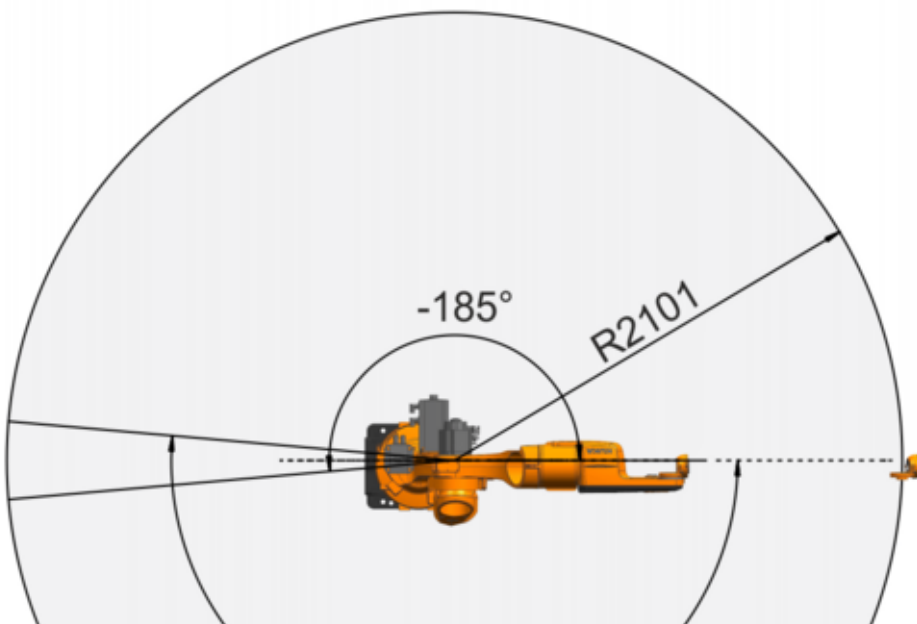
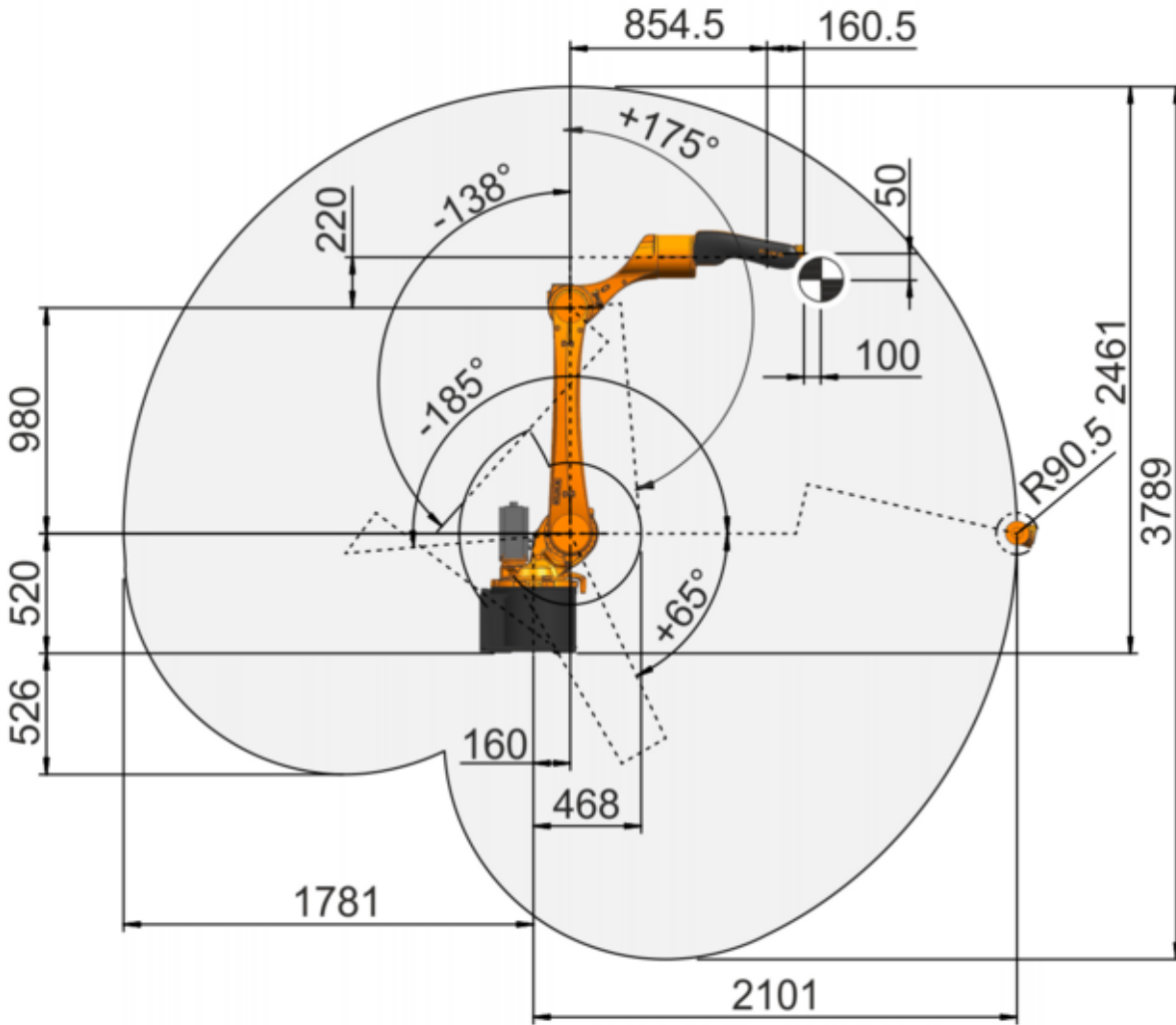

KR 8 R2100 arc HW 工作区域，整个

负载能力

额定负荷	8 kg
最大负载能力	-
法兰 I_x 额定质量转动惯量	0.1 kgm ²
法兰 I_y 额定质量转动惯量	0.1 kgm ²
法兰 I_z 额定质量转动惯量	0.1 kgm ²
底座的额定附加负载	0 kg
底座的最大附加负载	0 kg
转盘的额定附加负载	0 kg
旋转机构的最大附加负载	20 kg
大臂的额定附加负载	0 kg
大臂的最大附加负载	15 kg
小臂的额定附加负载	10 kg
小臂的最大附加负载	15 kg
负载重心额定距离	
L_{xy}	50 mm
L_z	100 mm

KR CYBERTECH ARC 负载能力图表, 负载能力 8kg

连接法兰

机器人腕部类型	ZH 8 HW
连接法兰	见图纸

Dimensions: mm

D - D

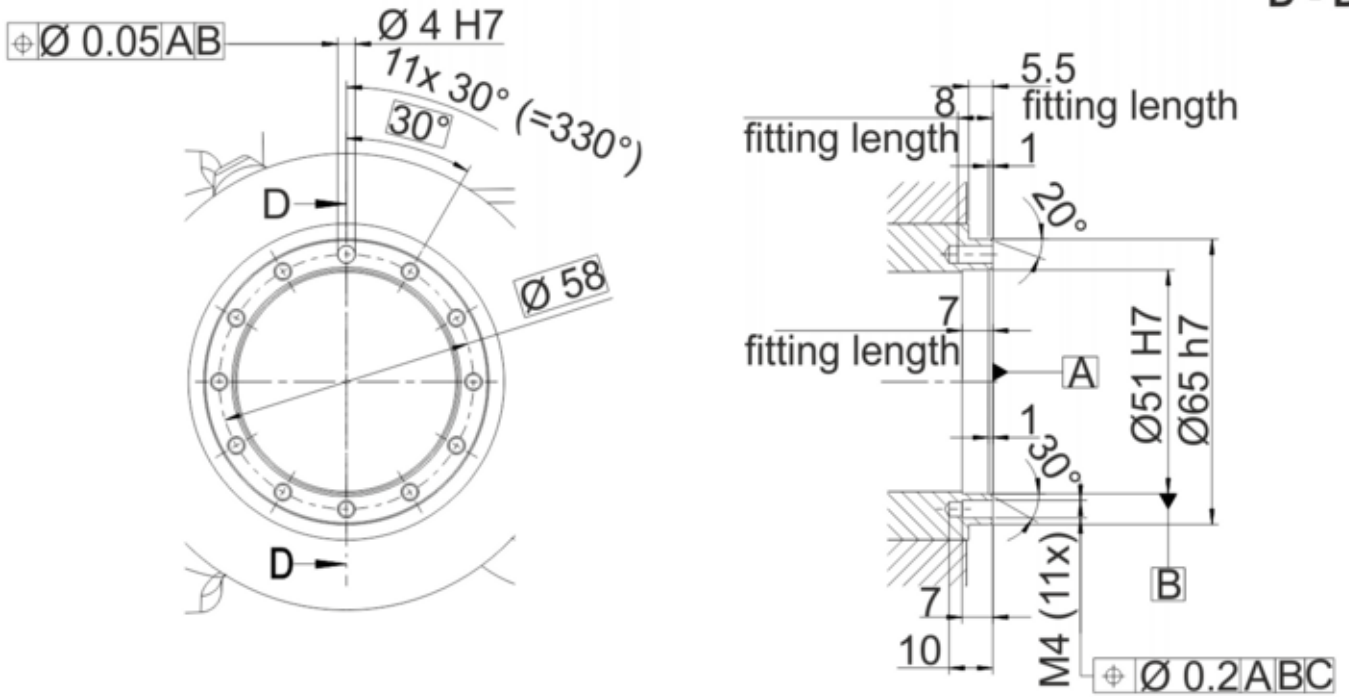

连接法兰

地基负载

地面安装位置时的地基负载	
F(v normal)	4038 N
F(v max)	4434 N
F(h normal)	2318 N
F(h max)	2988 N
M(k normal)	3334 Nm
M(k max)	4177 Nm
M(r normal)	1965 Nm
M(r max)	2361 Nm
天花板安装位置时的地基负载	
F(v normal)	4104 N
F(v max)	4535 N
F(h normal)	2272 N
F(h max)	2793 N
M(k normal)	3642 Nm
M(k max)	4553 Nm
M(r normal)	2017 Nm
M(r max)	2314 Nm
墙壁安装位置时的地基负载	
F(v normal)	4265 N
F(v max)	4461 N
F(h normal)	1464 N
F(h max)	2268 N
M(k normal)	4603 Nm
M(k max)	5124 Nm

M(r normal)	1739 Nm
M(r max)	2368 Nm

垂直力 $F(v)$ 、水平力 $F(h)$ 、倾斜力矩 $M(k)$ 、轴 1 的转矩 $M(r)$

Process forces

Process forces are forces that are exerted on the robot in a defined manner by an external influence. Causes include pressing processes and machining tasks carried out by the robot. The process forces that the robot can withstand depend to a very great degree on the robot position, payload, direction and duration of action. For this reason, it is not possible for a simple limit value to be specified for permissible process forces.

Permissible process torques are therefore specified for all axes of the robot. These values indicate the torque that each robot axis can withstand on a sustained basis as a result of external forces.

The following load torques must not be exceeded:

A1	1300 Nm
A2	575 Nm
A3	360 Nm
A4	30 Nm
A5	30 Nm
A6	25 Nm

精度数据

 仅适用于带定位精确的机器人选项（用于地面或天花板安装）的机器人在地面位置测量的机器人只允许在地面位置运行。这同样适用于天花板位置的机器人。

位置精度

位置绝对精度 (ISO 9283)	$\pm 0.5 \text{ mm}$
位姿重复精度 (ISO 9283)	$\pm 0.04 \text{ mm}$

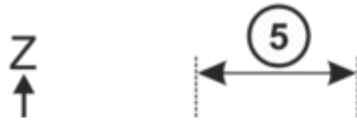

位置精度

1	编程设定的位置	4	测得的位置
2	位置绝对精度	5	位置重复精度
3	测得位置的平均值		

- 位置精度表示编程的机器人位置和实际占用的机器人位置之间的偏差，并用坐标测量机（CMM）在 9 个位置测量。
- 重复精度由重复 30 次测量时实际占用的机器人位置的偏差得出。
- 对于定位精确的机器人，这些值针对的是机器人基座。

轨迹精度

线性运动的轨迹精度:

LIN 轨迹绝对精度 (ISO 9283)	$\pm 0.6 \text{ mm}$
SLIN 轨迹绝对精度 (ISO 9283)	$\pm 0.5 \text{ mm}$
轨迹重复精度 线性 (ISO 9283)	$\pm 0.2 \text{ mm}$

该数据针对的是 1 m/s 的参考速度。

圆周运动的轨迹精度:

CIRC 轨迹绝对精度 (ISO 9283)	$\pm 0.5 \text{ mm}$
SCIRC 轨迹绝对精度 (ISO 9283)	$\pm 0.4 \text{ mm}$
圆周轨道重复精度 (ISO 9283)	$\pm 0.2 \text{ mm}$

该数据针对的是 0.5 m/s 的参考速度。

轨迹精度

1	轨迹绝对精度	3	运行轨迹的平均值
2	轨迹重复精度	4	编程的轨迹

- 轨迹精度表示机器人在编程的轨迹上运动的能力。
- 轨迹重复精度表示 10 个运行轨迹与运行轨迹平均值的偏差。

超调状态

振幅	0.5 mm
定位时间	0.2 s

超调状态

1	超调振幅	3	定位时间
2	公差范围		

- 超调振幅影响机器人在特定位置执行受控的精确暂停的能力。
- 定位时间表示机器人在特定位置上停止的速度。

更多的信息

- 给出的数据基于 ISO 9283，并使用 Krypton/Metris 的基于摄像机的系统测得。因此重复精度被定义为 3 sigma 值。
- 所有数值均以额定负载测得。

关税信息

统计货号	84795000
原产地	DE
制造商	KUKA Roboter
重量	255 kg

- > **KR 8 R2100 arc HW** 需要 (3)
- > **KR 8 R2100 arc HW** 带有如下的工具 (12)
- > **KR 8 R2100 arc HW** 带有如下的备件 (18)
- > **KR 8 R2100 arc HW** 有以下选项 (25)