



KUKA | Xpert

Identification number: AR5939

货号	0000-165-579
材料状态	10 - 批准预生产
制造商	KUKA Roboter
产品图片	

Spare parts

Pos.	Article number	Designation	Component	Controller
1	0000-265-025	SPP IW 1000 F	In-line wrist	
2	0000-148-407	Connecting shaft assy	Connecting shaft	
3	0000-212-326	AC servomotor TYPE-K/1FK7103 F	Motor A1	
4	0000-212-311	AC motor type A01/1FK7105 Foundry	Motor A2 Motor A3 Motor A4 Motor A5	
5	0000-212-310	AC motor type A0/1FK7103 Foundry	Motor A6	
6	0000-147-094	Hydraulic system	Counterbalancing system	
7	0000-117-152	Seal	Seal	
8	0000-167-690	Blanking plug SKINDICHT M32x1.5 assy	Blanking plug	
9	0000-162-424	Pressure regulator unit KR1000		
10	0000-221-808	Standard cable set assy Titan KRC4	Cable set	KR C4
	0000-197-703	safe cable set KR1000 compl. w. 15m ext.		KR C2 edition2005
	0000-168-540	Safe cable set assy KRXXL		KR C2 edition2005
	0000-168-512	Std cable set assy KRXXL		KR C2 edition2005 KR C2
11	0000-246-872	Resolver Digital Converter RDC	RDC	KR C4
12	0000-172-903	Electronic Data Storage EDS	EDS	KR C4
13	0000-194-084	Safe RDC w. I/O print spare part		KR C2 edition2005
14	0000-119-966	RDC 2 Resolver Digital Converter 120MHz		KR C2 edition2005 KR C2

Export to Excel 

Maintenance information

Gear oil



The quantity of oil drained depends on the draining time and the oil temperature. The refilling quantity is the quantity of oil that was drained from the gear unit at the correct operating temperature and with the correct draining time. This oil quantity must be determined. Only this quantity of oil may be used when refilling.

If less than 70 % of the specified oil quantity flows out, flush the gear unit with the determined quantity of drained oil once, then pour in the amount of oil that was drained. If less than 50% of the specified oil quantity flows out (e.g. inclined installation), the flushing operation must be repeated twice. During the flushing procedure, move the axis at jog velocity throughout the entire axis range.

The oil quantities specified in the table correspond to the oil quantities in the gear unit at first filling.

Gear oil new filling quantity	
A1	25.00 l
A2	24.00 l
A3	12.00 l
A4	10.00 l
A5	3.00 l
A6	10.00 l
Gear oil refilling quantity	
A1	22.50 l
A2	22.00 l
A3	9.20 l
A4	10.00 l
A5	2.80 l
A6	9.50 l

Counterbalancing system

Gas pressure p0	100 bar
Oil pressure p1	130 bar

技术数据

基本数据

	KR 1000 titan F
轴数	6
可控制的轴数	6
工作空间体积	79.8 m ³
位姿重复精度 (ISO 9283)	± 0.1 mm
重量	约 4700 kg
额定负荷	1000 kg
最大负载能力	-
最大运动范围	3202 mm
防护等级 (IEC 60529)	IP65
机器人腕部防护等级 (IEC 60529)	IP67
噪声等级	< 75 dB (A)
安装位置	地面
占地面积	-
运动系统安装面布孔图	C1300
允许倾角	-
标准色	底座： 黑色 (RAL 9005); 活动部件： 库卡橙色 2567
控制系统	KR C2 edition2005
变压器名称	KR C2: KR1000 H C2 FLR ZH1000; KR C4: KR1000 H C4 FLR

环境条件

湿度等级 (EN 60204)	-
环境条件分类 (EN 60721-3-3)	3K3
环境温度	
运行时	10 °C 至 55 °C (283 K 至 328 K)
仓储和运输时	-40 °C 至 60 °C (233 K 至 333 K)

轴数据

运动范围	
A1	±150 °
A2	-130 ° / 17.5 °
A3	-110 ° / 145 °
A4	±350 °
A5	±118 °
A6	±350 °
额定负载时的速度	
A1	58 °/s
A2	50 °/s
A3	50 °/s
A4	60 °/s
A5	60 °/s
A6	72 °/s

工作区域

Maße / Dimensions: mm

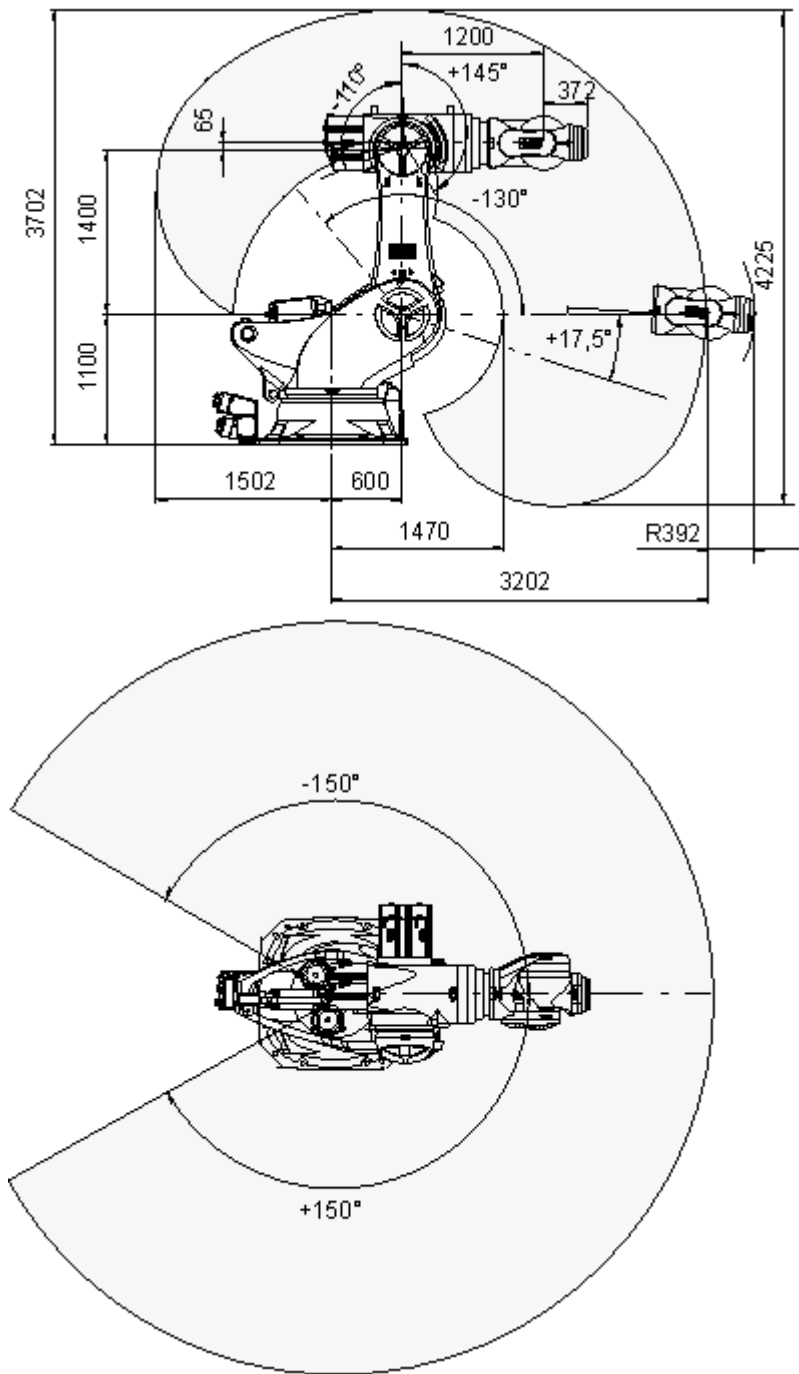

KR 1000 titan 的工作范围

负载能力

额定负荷	1000 kg
最大负载能力	-
法兰 Ix 额定质量转动惯量	500 kgm ²
法兰 Iy 额定质量转动惯量	500 kgm ²
法兰 Iz 额定质量转动惯量	500 kgm ²
底座的额定附加负载	0 kg
底座的最大附加负载	0 kg
转盘的额定附加负载	0 kg
旋转机构的最大附加负载	0 kg
大臂的额定附加负载	0 kg
大臂的最大附加负载	0 kg
小臂的额定附加负载	50 kg
小臂的最大附加负载	100 kg
负载重心额定距离	
Lxy	450 mm
Lz	400 mm

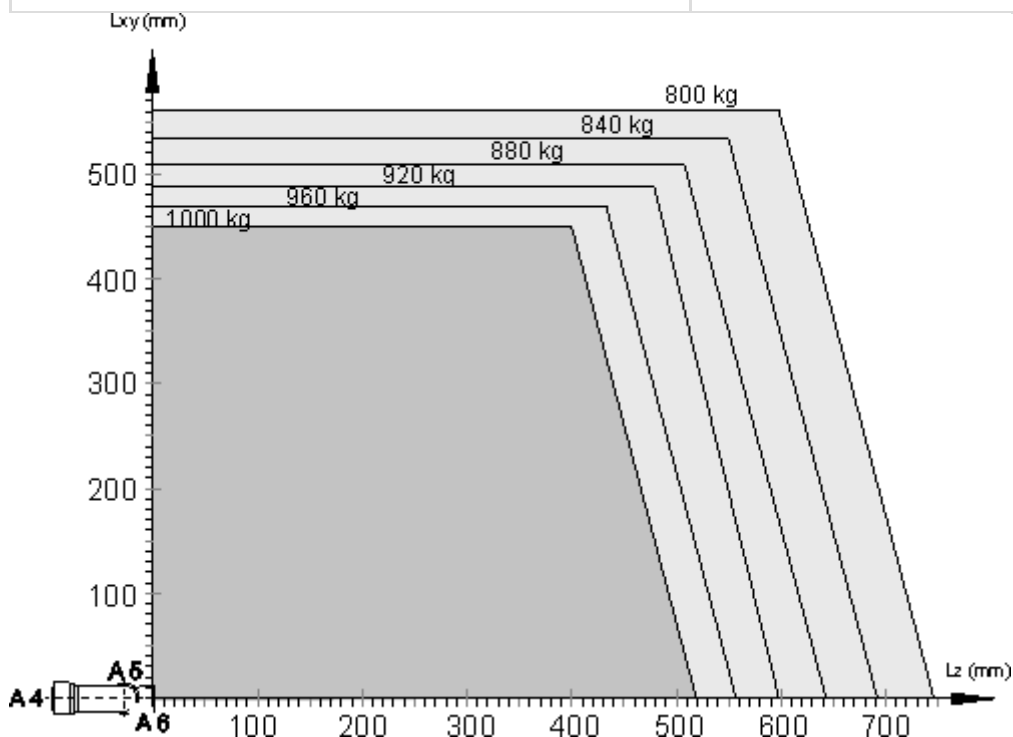

KR 1000 titan 和变型

连接法兰

机器人腕部类型	ZH 1000 F
连接法兰	见图纸

Dimensions: mm

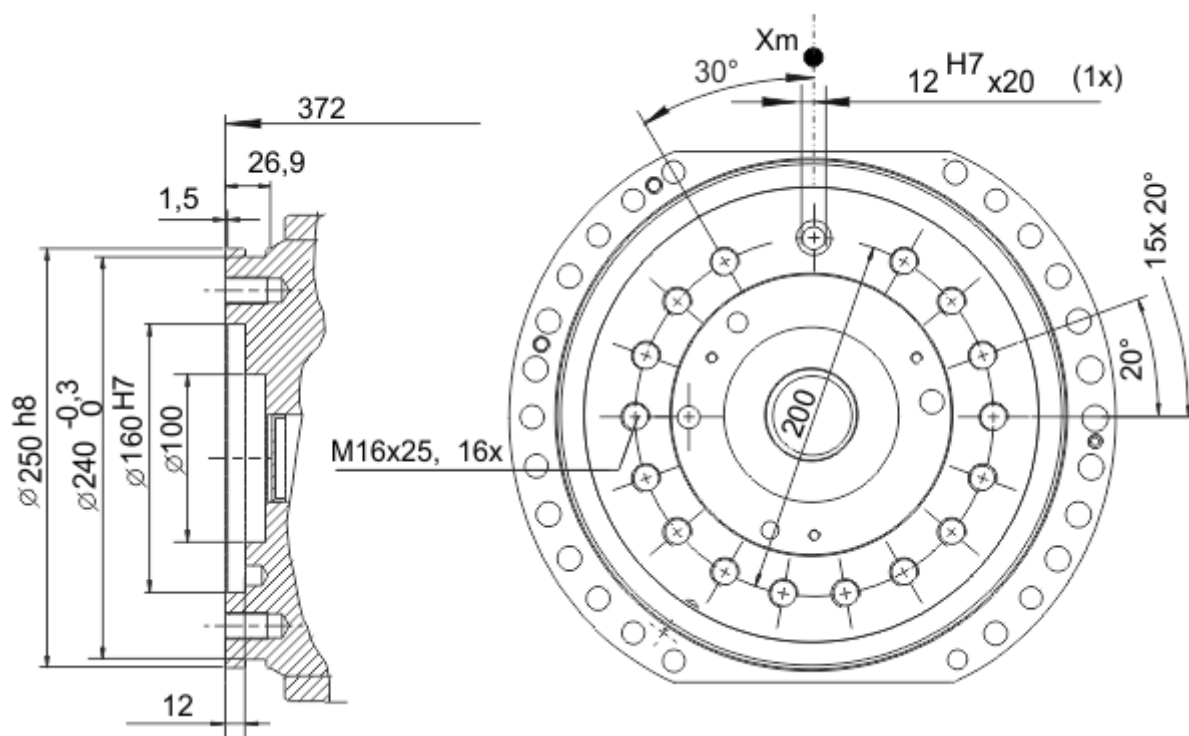

连接法兰

地基负载

纵向动力 F(v)	
F(v 正常)	61500 N
F(vmax)	70000 N
横向动力 F(h)	
F(h 正常)	21400 N
F(hmax)	35500 N
倾覆力矩 M(k)	
M(k 正常)	102200 Nm
M(kmax)	133700 Nm
轴 2 转矩 M(r)	
M(r 正常)	36600 Nm
M(rmax)	99700 Nm

垂直力 $F(v)$ 、水平力 $F(h)$ 、倾斜力矩 $M(k)$ 、轴 1 的转矩 $M(r)$

Process forces

Process forces are forces that are exerted on the robot in a defined manner by an external influence. Causes include pressing processes and machining tasks carried out by the robot. The process forces that the robot can withstand depend to a very great degree on the robot position, payload, direction and duration of action. For this reason, it is not possible for a simple limit value to be specified for permissible process forces.

Permissible process torques are therefore specified for all axes of the robot. These values indicate the torque that each robot axis can withstand on a sustained basis as a result of external forces.

The following load torques must not be exceeded:

A1	18000 Nm
A2	18000 Nm
A3	18000 Nm
A4	8800 Nm
A5	8800 Nm
A6	4450 Nm

Flange loads

Flange loads

Due to the motion of the payload (e.g. tool) mounted on the robot, forces and torques act on the mounting flange. These forces and torques depend on the motion profile as well as the mass, load center of gravity and mass moment of inertia of the payload.

The specified values refer to nominal payloads at the nominal distance and do not include safety factors. It is imperative for the load data to be entered in the robot controller. The robot controller takes the payload into consideration during path planning. A reduced payload does not necessarily result in lower forces and torques.

The values are guide values determined by means of trial and simulation and refer to the most heavily loaded machine in the robot family. The actual forces and torques may differ due to internal and external influences on the mounting flange or a different point of application. It is therefore advisable to determine the exact forces and torques where necessary on site under the real conditions of the actual robot application.

The operating values may occur permanently in the normal motion profile. It is advisable to rate the tool for its fatigue strength.

The EMERGENCY STOP values may arise in the event of an Emergency Stop situation of the robot. As these should only occur very rarely during the service life of the robot, a static strength verification is usually sufficient.

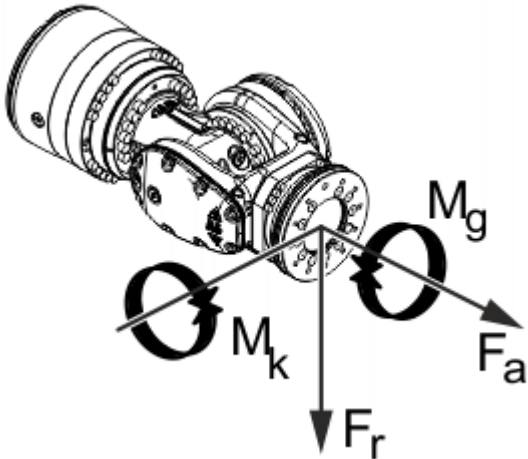

Flange loads

Flange loads during operation	
F(a)	11200 N
F(r)	15000 N
M(k)	3300 Nm

M(g)	5400 Nm
Flange loads in the case of EMERGENCY STOP	
F(a)	12650 N
F(r)	24750 N
M(k)	9350 Nm
M(g)	8050 Nm

Axial force $F(a)$, radial force $F(r)$, tilting torque $M(k)$, torque about mounting flange $M(g)$

轨迹精度

线性运动的轨迹精度:

LIN 轨迹绝对精度 (ISO 9283)	$\pm 2.2 \text{ mm}$
SLIN 轨迹绝对精度 (ISO 9283)	-
轨迹重复精度 线性 (ISO 9283)	$\pm 0.3 \text{ mm}$

该数据针对的是 1 m/s 的参考速度。

圆周运动的轨迹精度:

CIRC 轨迹绝对精度 (ISO 9283)	$\pm 1.5 \text{ mm}$
SCIRC 轨迹绝对精度 (ISO 9283)	-
圆周轨道重复精度 (ISO 9283)	$\pm 0.25 \text{ mm}$

该数据针对的是 0.5 m/s 的参考速度。

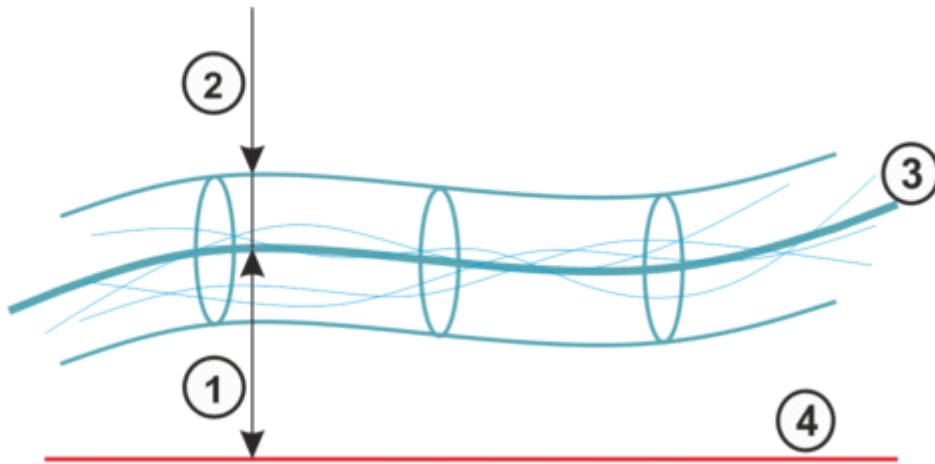

轨迹精度

1	轨迹绝对精度	3	运行轨迹的平均值
2	轨迹重复精度	4	编程的轨迹

- 轨迹精度表示机器人在编程的轨迹上运动的能力。
- 轨迹重复精度表示 10 个运行轨迹与运行轨迹平均值的偏差。

超调状态

振幅	1.4 mm
定位时间	0.6 s

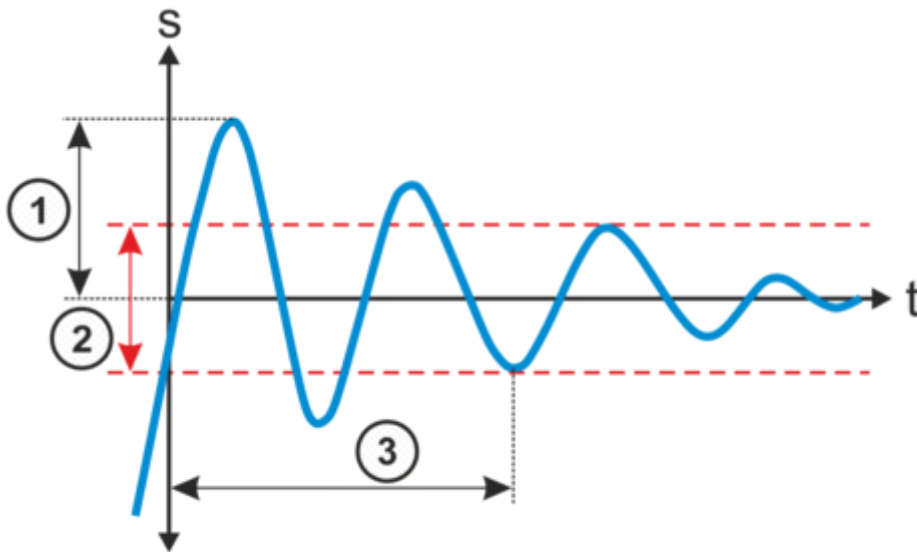

超调状态

1	超调振幅	3	定位时间
2	公差范围		

- 超调振幅影响机器人在特定位置执行受控的精确暂停的能力。
- 定位时间表示机器人在特定位置上停止的速度。

更多的信息

- 给出的数据基于 ISO 9283，并使用 Krypton/Metris 的基于摄像机的系统测得。因此重复精度被定义为 3 sigma 值。
- 所有数值均以额定负载测得。

Dangerous goods information

The following parts of the product must be considered dangerous goods with regard to their transportation in public spaces:

Pos.	Article number	Designation	Nitrogen mass
1	0000-147-094	Hydraulic system	kg

Export to Excel 

For sea or air freight, the following UN number shall apply:

UN 3164 Articles, pressurized, hydraulic (with non-flammable, non-toxic gases)

UN number	UN 3164
Proper shipping name	Articles, pressurized, hydraulic (with non-flammable, non-toxic gases)
Class	2.2
Explanation of class	Non-flammable, non-toxic gases
Example	Filled hydropneumatic CBSs
Hazard	<ul style="list-style-type: none"> • Bursting of the pressure vessels (100 - 160 bar) • Splintering not possible • Freezing due to sudden escape of gas
Measures	<ul style="list-style-type: none"> • Do not loiter in low-lying areas • If possible, drain oil and depressurize CBS

关税信息

统计货号	84795000
原产地	DE
制造商	KUKA ROBOTER
重量	4700 kg

- > **KR 1000 titan F** 带有如下的工具 (21)
- > **KR 1000 titan F** 有以下选项 (18)
- > **KR 1000 titan F** 带有如下的标准组件 (4)
- > **KR 1000 titan F** 包含以下危险品 (1)
- > **KR 1000 titan F** 需要 (16)
- > **KR 1000 titan F** 带有如下的备件 (15)