

KUKA | Xpert

Identification number: AR5943

货号	0000-167-736
材料状态	10 - 批准预生产
制造商	KUKA Roboter
产品图片	

Spare parts

Pos.	Article number	Designation	Component	Controller
1	0000-265-024	SPP IW 1000	In-line wrist	
2	0000-148-407	Connecting shaft assy	Connecting shaft	
3	0000-197-799	SPP motor 8.6 kW	Motor A2 Motor A3 Motor A4 Motor A5	
4	0000-119-768	ME 250 180 37 S0	Motor A1	
5	0000-131-492	ME_360_180_30_S0	Motor A6	
6	0000-147-094	Hydraulic system	Counterbalancing system	
7	0000-221-808	Standard cable set assy Titan KRC4	Cable set	KR C4
	0000-197-703	safe cable set KR1000 compl. w. 15m ext.		KR C2 edition2005
	0000-168-540	Safe cable set assy KRXXL		KR C2 edition2005
	0000-168-512	Std cable set assy KRXXL		KR C2 edition2005 KR C2
8	0000-246-872	Resolver Digital Converter RDC	RDC	KR C4
9	0000-172-903	Electronic Data Storage EDS	EDS	KR C4
10	0000-194-084	Safe RDC w. I/O print spare part		KR C2 edition2005
11	0000-119-966	RDC 2 Resolver Digital Converter 120MHz		KR C2 edition2005 KR C2

Export to Excel 

Maintenance information

Gear oil



The quantity of oil drained depends on the draining time and the oil temperature. The refilling quantity is the quantity of oil that was drained from the gear unit at the correct operating temperature and with the correct draining time. This oil quantity must be determined. Only this quantity of oil may be used when refilling.

If less than 70 % of the specified oil quantity flows out, flush the gear unit with the determined quantity of drained oil once, then pour in the amount of oil that was drained. If less than 50% of the specified oil quantity flows out (e.g. inclined installation), the flushing operation must be repeated twice. During the flushing procedure, move the axis at jog velocity throughout the entire axis range.

The oil quantities specified in the table correspond to the oil quantities in the gear unit at first filling.

Gear oil new filling quantity	
A1	25.00 l
A2	24.00 l
A3	12.00 l
A4	10.00 l
A5	3.00 l
A6	10.00 l
Gear oil refilling quantity	
A1	22.50 l
A2	22.00 l
A3	9.20 l
A4	10.00 l
A5	2.80 l
A6	9.50 l

Counterbalancing system

Gas pressure p0	100 bar
Oil pressure p1	130 bar

技术数据

基本数据

	KR 1000 1300 titan PA
轴数	4
可控制的轴数	4
工作空间体积	69.5 m ³
位姿重复精度 (ISO 9283)	± 0.1 mm
重量	约 4690 kg
额定负荷	1300 kg
最大负载能力	-
最大运动范围	3202 mm
防护等级 (IEC 60529)	IP65
机器人腕部防护等级 (IEC 60529)	IP65
噪声等级	< 75 dB (A)
安装位置	地面
占地面积	-
运动系统安装面布孔图	C1300
允许倾角	-
标准色	底座： 黑色 (RAL 9005); 活动部件： 库卡橙色 2567
控制系统	KR C2 edition2005
变压器名称	KR C2: KR1300PA H C2 FLR ZH1000; KR C4: KR1300PA H C4 FLR

环境条件

湿度等级 (EN 60204)	-
环境条件分类 (EN 60721-3-3)	3K3
环境温度	
运行时	5 °C 至 55 °C (278 K 至 328 K)
仓储和运输时	-40 °C 至 60 °C (233 K 至 333 K)

轴数据

运动范围	
A1	±150 °
A2	-130 ° / 17.5 °
A3	62 ° / 145 °
A4	-
A5	±118 °
A6	±350 °
额定负载时的速度	
A1	58 °/s
A2	50 °/s
A3	50 °/s
A4	-
A5	60 °/s
A6	72 °/s

工作区域

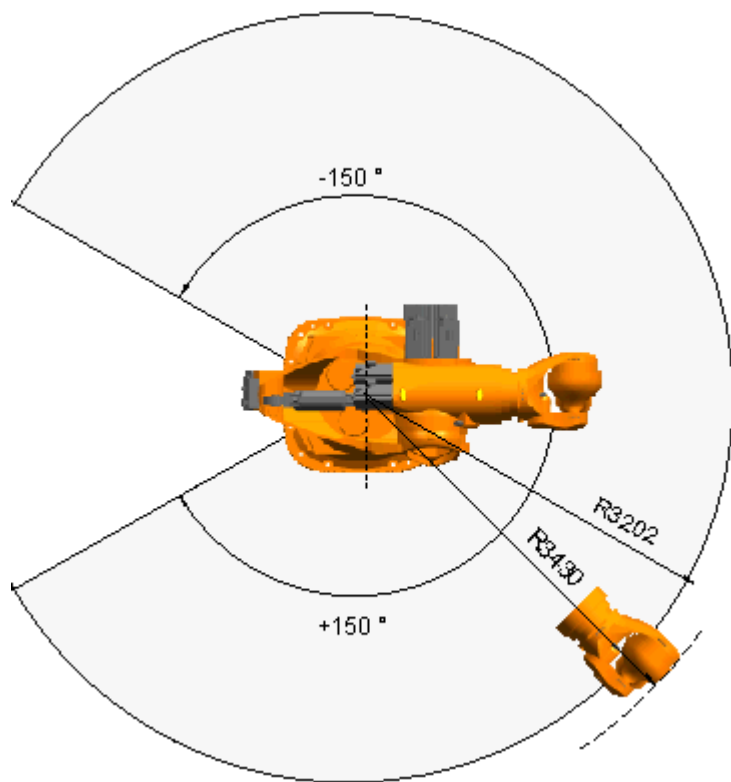
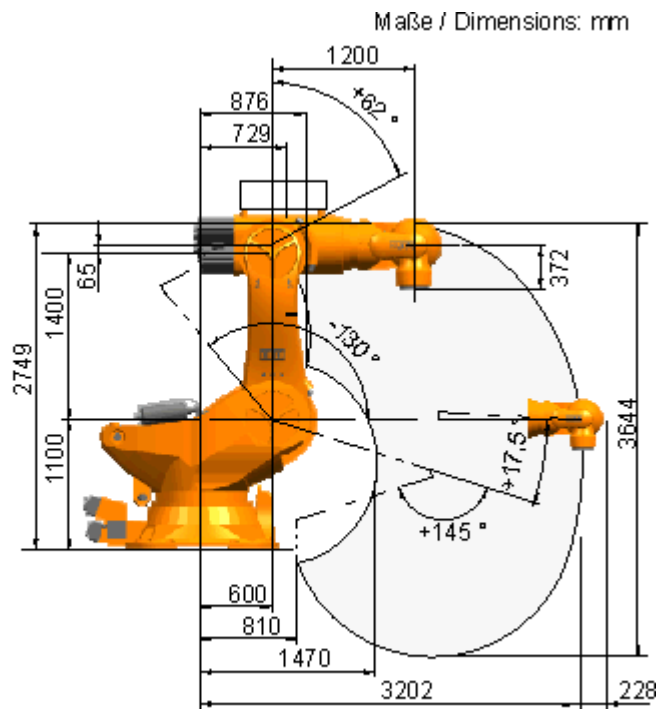

KR 1000 1300 titan PA 工作区域

负载能力

额定负荷	1300 kg
最大负载能力	-
法兰 I_x 额定质量转动惯量	650 kgm ²
法兰 I_y 额定质量转动惯量	650 kgm ²
法兰 I_z 额定质量转动惯量	650 kgm ²
底座的额定附加负载	0 kg
底座的最大附加负载	0 kg
转盘的额定附加负载	0 kg
旋转机构的最大附加负载	0 kg
大臂的额定附加负载	0 kg
大臂的最大附加负载	0 kg
小臂的额定附加负载	50 kg
小臂的最大附加负载	100 kg
负载重心额定距离	
L_{xy}	150 mm
L_z	400 mm

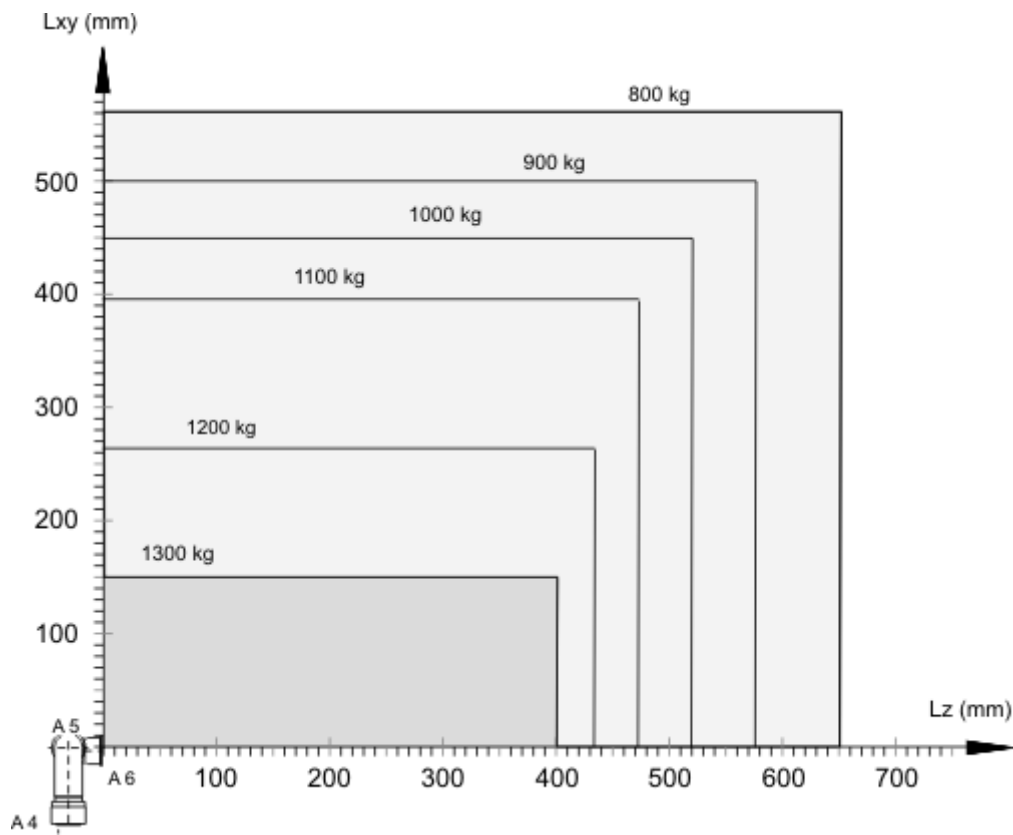

KR 1000 1300 titan PA 和变型

地基负载

纵向动力 F(v)	
F(v 正常)	61500 N
F(vmax)	70000 N
横向动力 F(h)	
F(h 正常)	21400 N
F(hmax)	35500 N
倾覆力矩 M(k)	
M(k 正常)	102200 Nm
M(kmax)	133700 Nm
轴 2 转矩 M(r)	
M(r 正常)	36600 Nm
M(rmax)	99700 Nm

垂直力 $F(v)$ 、水平力 $F(h)$ 、倾斜力矩 $M(k)$ 、轴 1 的转矩 $M(r)$

Flange loads

Flange loads

Due to the motion of the payload (e.g. tool) mounted on the robot, forces and torques act on the mounting flange. These forces and torques depend on the motion profile as well as the mass, load center of gravity and mass moment of inertia of the payload.

The specified values refer to nominal payloads at the nominal distance and do not include safety factors. It is imperative for the load data to be entered in the robot controller. The robot controller takes the payload into consideration during path planning. A reduced payload does not necessarily result in lower forces and torques.

The values are guide values determined by means of trial and simulation and refer to the most heavily loaded machine in the robot family. The actual forces and torques may differ due to internal and external influences on the mounting flange or a different point of application. It is therefore advisable to determine the exact forces and torques where necessary on site under the real conditions of the actual robot application.

The operating values may occur permanently in the normal motion profile. It is advisable to rate the tool for its fatigue strength.

The EMERGENCY STOP values may arise in the event of an Emergency Stop situation of the robot. As these should only occur very rarely during the service life of the robot, a static strength verification is usually sufficient.

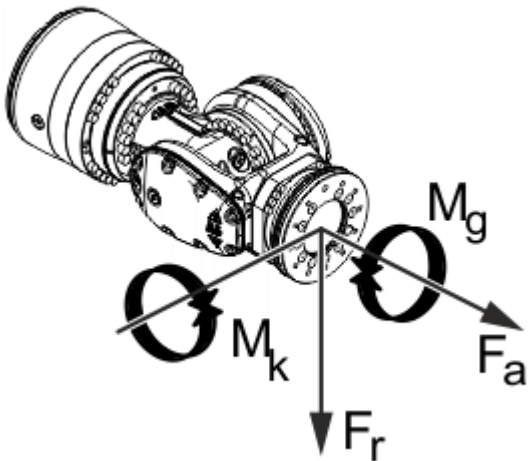

Flange loads

Flange loads during operation	
F(a)	-
F(r)	-
M(k)	-

M(g)	-
Flange loads in the case of EMERGENCY STOP	
F(a)	-
F(r)	-
M(k)	-
M(g)	-

Axial force $F(a)$, radial force $F(r)$, tilting torque $M(k)$, torque about mounting flange $M(g)$

Dangerous goods information

The following parts of the product must be considered dangerous goods with regard to their transportation in public spaces:

Pos.	Article number	Designation	Nitrogen mass
1	0000-147-094	Hydraulic system	kg

Export to Excel 

For sea or air freight, the following UN number shall apply:

UN 3164 Articles, pressurized, hydraulic (with non-flammable, non-toxic gases)

UN number	UN 3164
Proper shipping name	Articles, pressurized, hydraulic (with non-flammable, non-toxic gases)
Class	2.2
Explanation of class	Non-flammable, non-toxic gases
Example	Filled hydropneumatic CBSs
Hazard	<ul style="list-style-type: none"> • Bursting of the pressure vessels (100 - 160 bar) • Splintering not possible • Freezing due to sudden escape of gas
Measures	<ul style="list-style-type: none"> • Do not loiter in low-lying areas • If possible, drain oil and depressurize CBS

关税信息

统计货号	84795000
原产地	DE
制造商	KUKA ROBOTER
重量	4690 kg

- > **KR 1000 1300 titan PA** 带有如下的工具 (21)
- > **KR 1000 1300 titan PA** 有以下选项 (18)
- > **KR 1000 1300 titan PA** 带有如下的标准组件 (4)
- > **KR 1000 1300 titan PA** 包含以下危险品 (1)
- > **KR 1000 1300 titan PA** 需要 (16)
- > **KR 1000 1300 titan PA** 带有如下的备件 (14)